

# CONTRACT DOCUMENTS

## Specification No. 2020-15

### STRUCTURAL PILE REPAIRS TO NAVY PIER SAN DIEGO, CALIFORNIA



***Procurement Services Department  
San Diego Unified Port District's General Services Building  
1400 Tidelands Avenue  
National City, California 91950***

**Procurement Analyst II**

**Mark Adams**

All questions regarding these contract documents shall be directed to the Contracts Administrator  
Telephone: (619) 686-6247  
Fax: (619) 686-6565  
madams@portofsandiego.org

### **KEY DATES**

<b>Issued:</b>	<b>January 13, 2022</b>
<b>Pre-Bid Conference:</b>	<b>January 20, 2022 @ 2:00 p.m.</b>
<b>Site Visit RSVP</b>	<b>January 25, 2022 @ 10:00 am</b>
<b>Questions Due By:</b>	<b>February 8, 2022 @ 2:00 p.m.</b>
<b>Bid Opening:</b>	<b>February 22, 2022 @ 2:00 p.m.</b>
<b>Original Documents Submitted By:</b>	<b>February 23, 2022 @ 4:00 p.m.</b>
<b>Proposed Board Approval:</b>	<b>March 8, 2022 @ 1:00 p.m.</b>

**PROJECT NO. MC-0082-01**

## TABLE OF CONTENTS

PAGE NO.

<b>SECTION 1.0 – NOTICE INVITING BIDS .....</b>	<b>1</b>
NOTICE INVITING BIDS.....	1
<b>SECTION 2.0 – BID FORMS (SEE BID PROPOSAL PACKAGE).....</b>	<b>3</b>
PROPOSAL .....	4
CONTRACTOR'S LICENSE INFORMATION/STATUS .....	6
NONCOLLUSION AFFIDAVIT TO BE EXECUTED BY BIDDER AND SUBMITTED WITH BID .....	7
BID SCHEDULE.....	8
SUBCONTRACTOR LISTING INFORMATION .....	9
BIDDER'S STATEMENT OF EXPERIENCE .....	10
QUESTIONNAIRE FOR BIDDER'S STATEMENT OF EXPERIENCE.....	11
BIDDER'S CERTIFICATE OF WORKER'S COMPENSATION.....	13
FALSE CLAIMS CERTIFICATION.....	14
RESPONDENT'S CERTIFICATE OF COMPLIANCE WITH AMERICANS WITH DISABILITIES ACT .....	15
SBE SUB-PARTICIPATION FORM .....	16
SBE SUB-PARTICIPATION ACKNOWLEDGEMENT FORM .....	16a
<b>SECTION 3.0 – CONTRACT FORMS.....</b>	<b>17</b>
CONTRACT .....	18
FAITHFUL PERFORMANCE BOND AND LABOR AND MATERIALMEN'S BOND .....	20
<b>SECTION 4.0 – INSTRUCTIONS TO BIDDERS.....</b>	<b>22</b>
<b>ARTICLE 4.1 – PRE-BID OPENING INSTRUCTIONS.....</b>	<b>22</b>
4.1.1 ELECTRONIC PLANS AND SPECIFICATIONS .....	22
4.1.2 EXAMINATION OF PLANS, SPECIFICATIONS AND WORK SITE .....	22
4.1.3 INTERPRETATION OF DRAWINGS AND DOCUMENTS .....	23
4.1.4 ADDENDA.....	23
4.1.5 BIDDERS INTERESTED IN MORE THAN ONE BID .....	23
4.1.6 ELECTRONIC BIDDING .....	23
4.1.7 PROPOSALS .....	24
<b>ARTICLE 4.2 – BID OPENING.....</b>	<b>25</b>
4.2.1 OPENING OF BIDS .....	25
4.2.2 AWARD OR REJECTION OF BIDS.....	25
4.2.3 BID PROTESTS .....	25
<b>ARTICLE 4.3 – AWARD.....</b>	<b>25</b>
4.3.1 THE CONTRACT .....	25
<b>ARTICLE 4.4 – NOTICE TO BIDDERS.....</b>	<b>26</b>
4.4.1 EMPLOYMENT OF APPRENTICES.....	26
4.4.2 EQUAL EMPLOYMENT OPPORTUNITY AND NON-DISCRIMINATION CLAUSE .....	26
4.4.3 PUBLIC WORKS CONTRACTOR REGISTRATION PROGRAM .....	26
<b>SECTION 5.0 – GENERAL CONDITIONS.....</b>	<b>28</b>
<b>ARTICLE 5.1 – GENERAL PROVISIONS .....</b>	<b>28</b>
5.1.1 THE CONTRACT .....	28
5.1.2 DEFINITION OF TERMS .....	28
5.1.3 INCORPORATION .....	29

## TABLE OF CONTENTS

### PAGE NO.

5.1.4	DIVISIONS OF PLANS AND SPECIFICATIONS .....	29
5.1.5	EFFECT OF PLANS AND SPECIFICATIONS .....	30
5.1.6	PRECEDENCE OF DOCUMENTS .....	30
5.1.7	INTERPRETATION/NOTIFICATION REQUIREMENTS .....	30
5.1.8	OWNERSHIP AND USE OF DRAWINGS, SPECIFICATIONS AND OTHER DOCUMENTS .....	31
<b>ARTICLE 5.2 – DISTRICT .....</b>		<b>31</b>
5.2.1	DISTRICT’S RIGHT TO STOP WORK .....	31
5.2.2	DISTRICT’S RIGHT TO CARRY OUT THE WORK .....	31
5.2.3	NO WAIVER OF RIGHTS .....	31
5.2.4	DISTRICT’S ADMINISTRATION OF THE CONTRACT .....	32
5.2.5	AUTHORITY OF ENGINEER.....	32
5.2.6	DISTRICT’S OBSERVATION OF WORK .....	32
5.2.7	DEFECTIVE WORK – NOTICE TO CONTRACTOR.....	33
5.2.8	ACCEPTANCE OF NONCOMFORMING WORK .....	33
5.2.9	RECEIPT OF THIRD PARTY CLAIMS .....	33
<b>ARTICLE 5.3 – CONTRACTOR .....</b>		<b>33</b>
5.3.1	REVIEW OF CONTRACT AND FIELD CONDITIONS .....	33
5.3.2	SUPERVISION AND CONSTRUCTION PROCEDURES .....	34
5.3.3	LABOR AND PREVAILING WAGES .....	35
5.3.4	SUBMITTALS.....	37
5.3.5	MATERIALS AND SAMPLES .....	38
5.3.6	GUARANTEE .....	38
5.3.7	SCHEDULES .....	38
5.3.8	RECORD DRAWINGS AND TESTS.....	39
5.3.9	UTILITIES.....	40
5.3.10	RIGHT-OF-WAY.....	40
5.3.11	SANITATION.....	40
5.3.12	PRESERVATION OF MONUMENT .....	40
5.3.13	DATUM PLANE AND MEASUREMENTS.....	40
5.3.14	SETTING STAKES.....	40
5.3.15	TRENCHES OR OTHER EXCAVATION AND HAZARDOUS OR CONTAMINATED CONDITIONS.....	40
5.3.16	EXISTING UTILITIES, IMPROVEMENTS AND OBSTRUCTIONS.....	41
5.3.17	ROYALTIES AND PATENTS .....	42
5.3.18	INDEMNIFICATION .....	43
5.3.19	ASSIGNMENT OF CONTRACT .....	44
5.3.20	ANTITRUST CLAIMS.....	44
5.3.21	BANKRUPTCY OF CONTRACTOR .....	44
5.3.22	CONTACT WITH MEDIA .....	44
5.3.23	CLEANING UP .....	44
<b>ARTICLE 5.4 – SUBCONTRACTORS.....</b>		<b>45</b>
5.4.1	REQUIREMENTS AT BID.....	45
5.4.2	SUBCONTRACTUAL RELATIONS .....	45
<b>ARTICLE 5.5 – PROTECTION OF PERSONS AND PROPERTY .....</b>		<b>46</b>
5.5.1	SAFETY PRECAUTIONS AND PROGRAMS.....	46
5.5.2	ACCIDENT PREVENTION, BARRICADES, LIGHTS, SAFETY MEASURES AND DETOURS.....	46
5.5.3	EMERGENCIES.....	47
5.5.4	CARE AND CUSTODY OF WORK/LOSS AND DAMAGE.....	47

**TABLE OF CONTENTS**

**PAGE NO.**

<b>ARTICLE 5.6 – INSURANCE AND BONDS .....</b>	<b>48</b>
5.6.1 CONTRACTOR’S INSURANCE .....	48
5.6.2 PERFORMANCE AND LABOR AND MATERIAL BONDS.....	49
<b>ARTICLE 5.7 – CHANGES IN THE WORK .....</b>	<b>50</b>
5.7.1 CHANGES AND EXTRA WORK.....	50
5.7.2 FORM OF CHANGES .....	50
5.7.3 BILATERAL CHANGES .....	50
5.7.4 UNILATERAL CHANGE ORDERS .....	52
5.7.5 PRICING FOR ALL TYPES OF CHANGES.....	52
5.7.6 AUDIT.....	54
<b>ARTICLE 5.8 – TIME .....</b>	<b>55</b>
5.8.1 PROGRESS AND COMPLETION .....	55
5.8.2 LIQUIDATED DAMAGES.....	56
5.8.3 DELAYS AND EXTENSIONS OF TIME.....	57
<b>ARTICLE 5.9 – PAYMENTS AND COMPLETION.....</b>	<b>59</b>
5.9.1 PERIODIC PAYMENTS .....	59
5.9.2 APPLICATIONS FOR PAYMENT (PROGRESS ESTIMATES) .....	60
5.9.3 ACCEPTANCE AND PAYMENT .....	60
5.9.4 PARTIAL UTILIZATION AND BENEFICIAL OCCUPANCY .....	61
5.9.5 QUANTITY UNITS, PAYMENTS AND MEASUREMENTS .....	61
<b>ARTICLE 5.10 – CLAIMS AND DISPUTES .....</b>	<b>63</b>
5.10.1 CLAIMS AND DISPUTES .....	63
5.10.2 CONSTRUCTION CLAIMS LESS THAN \$375,000.....	64
<b>ARTICLE 5.11 – TERMINATION OR SUSPENSION OF THE CONTRACT.....</b>	<b>66</b>
5.11.1 TERMINATION OR SUSPENSION OF CAUSE .....	66
5.11.2 TERMINATION OR SUSPENSION FOR CONVENIENCE .....	67
5.11.3 EFFECT OF SUSPENSION, INTERRUPTION OR TERMINATION .....	67
<b>SECTION 6.0 – TECHNICAL SPECIFICATIONS</b>	
<b>SECTION 7.0 – APPENDICES / EXHIBITS</b>	

## SECTION 1.0 – NOTICE INVITING BIDS

Notice is hereby given that the Procurement Services Department, General Services Building, First Floor, of the Port of San Diego (Port) will receive electronic bids at 1400 Tidelands Avenue, National City, California, until **2:00 P.M.** on the **22<sup>nd</sup>** day of **February, 2022** for:

**Specification No.: 2020-15 - Drawing No. EM-2020-03**

### **SCOPE OF WORK:**

The Contractor shall provide all equipment, supervision, management, labor, materials and systems necessary to perform the following work:

- Pier mark out, dive survey and other preconstruction surveys, including calculations of under deck repair quantities and form lengths.
- Full length encasement of 20-inch square concrete piles designated to be installed from EL. 8.5 to minimum 2 feet embedment below seabed including pile cleaning, excavation, backfill, forming, grouting, inspection and testing (257 piles, approximately 6300 linear feet of form).
- Remove and dispose of pipe debris and relocate and reinstall rock at locations on underwater slope where interferes with pile encasement (35 piles)
- Repair concrete at beams, pile caps, pile tops, soffit, low caps, and retaining walls including removal of unsound concrete, replace reinforcing steel when required, forming and placement of repair material, inspection and testing (695 areas, approximately 2200 cubic feet)
- Epoxy-inject repair of miscellaneous cracks found during preconstruction survey at beams, pile caps, pile tops, soffit, low caps, and retaining walls (approximately 500 linear feet).

### **CONTRACTOR RELEVANT EXPERIENCE:**

Supply and installation of the pile encapsulation system is limited to Contractors and Manufacturers with proven experience and shall meet the following minimum requirements:

- The Contractor shall have a minimum of 5 years of experience in pile repair and installation of pile encapsulation systems.
- The Contractor shall have experience with a minimum of two projects using the proposed pile encapsulation system within the past 5 years, with at least two projects of similar complexity to this project.
- Demonstrate availability of experienced installation personnel from the Contractor dedicated to this Work. Provide a foreman with a minimum of five years of experience in the installation of the pile encapsulation system, who have supervised the installation of at least three projects using the pile encapsulation system, with at least one project of similar complexity to this project.

The total contract duration is 540 calendar days. The Engineer's Construction estimate for this work is **\$11,200,000.00**.

The bidder must possess a valid California State Contractors License **Classification A**, "**General Engineering Contractor**", at the time the contract is submitted.

Bids will be opened in public at or about that hour at 1400 Tidelands Avenue, National City, California, all as more particularly contained in **Document No. 73442** on file in the Office of the District Clerk of the Port. No Bidder may withdraw a bid after the date set for bid opening.

Plans and specifications are available for download on the Port of San Diego website, <https://pbsystem.planetbids.com/portal/13982/bo/bo-search>. For assistance in downloading these documents feel free to contact the Procurement Services Department at 619-686-6392.

Bidders must register as a vendor at the following website in order to download specification, Bid Proposal Package, plans, and prospective bidders list, and to receive addendums and notifications when issued.

<https://pbsystem.planetbids.com/portal/13982/portal-home>

Bidder shall submit their original Bid Proposal Package to the Procurement Services Department, 1400 Tidelands Avenue, National City, California 91950 within the date stated on the Contract Documents page after electronic bidding (See Section 4.0, Instruction to Bidders).

A **pre-bid conference** will be conducted at **2:00 p.m. on January 20, 2022 VIRTUALLY ONLY. This meeting can be accessed by dialing 619-535-7686, and use Conference ID: 647 548 245# or by using the following link: [Click here to join the meeting](#)** (see eBid system for URL, if needed). The Port's representative will be present at the pre-bid conference. **No questions will be allowed during the pre-bid conference.**

**Site Visit.** A site visit will be arranged for interested parties. **Those interested must RSVP** for site visit by using the following link: <https://forms.office.com/r/1tTvURjr16> **no later than January 25, 2022 at 10:00 a.m.** Due to capacity restrictions for the site visit, a maximum of two (2) representatives from each company may attend a site visit. After receiving all RSVP's, Port staff will make arrangements for site visit with individuals on the RSVP list. Regarding COVID regulations: If you are not fully vaccinated we ask that face coverings are worn in areas that social distance can not be maintained, which would include this Site Visit.

Attendance at a site visit is not mandatory, however, all prospective Proposers are encouraged to attend. Submission of a Bid Proposal Package shall be evidence that the bidder has visited the jobsite and is satisfied with the conditions to be encountered if awarded the contract.

**Questions or comments** regarding this specification must be submitted electronically to our eBid system where the specification was downloaded and must be received by the Port no later than **February 8, 2022 at 2:00 p.m.** Questions received after the date stated here will not be accepted. Emails and faxes will not be accepted. Responses from the Port will be communicated via the electronic eBid system to all recipients of this specification.

In accordance with the provisions of the California State Labor Code, the Port has obtained the general prevailing rate of wages (which rate includes employer payments for health and welfare, vacation, pension and similar purposes) applicable to the work to be done, for straight time, overtime, Saturday, Sunday and holiday work. All labor employed on this project shall be paid no less than such minimum rates of wages. These wage rates are available for inspection at the office of the Procurement Services Department of the Port of San Diego.

It is the policy of the Port of San Diego that certified Small Business Enterprises (SBEs) shall have the maximum opportunity to participate in the performance of District Contracts. The SBE participation goal for this proposal/bid/quote is **5% (five percent)**. Certified SBEs with qualifying experience are encouraged to respond to the request for proposals/bids/quotes, etc.

Award of the contract, if made, will be within 120 calendar days after bid opening date. A bid guarantee in accordance with Subsection 5.6.2 of the General Condition is required with submission of a bid. No Bidder may withdraw a bid after the date set for bid opening.

Bidder shall file the bonds as required by the Contract and Civil Code section 9554. The provisions of Public Contract Code section 22300 apply to this Contract.

Bidders are hereby notified that the successful Bidder will be required to provide insurance in accordance with Subsection 5.6.1, "Contractor's Insurance," of the Section 5.0, General Condition.

A Notification Regarding Environmental Conditions has been included as Exhibit A in the project specifications. This notification will serve as the District's disclosure regarding potential hazardous materials that may be encountered during grading, excavation, trenching, and/or other ground penetration.

In the public interest, the District reserves the right to reject any or all bids, or to waive any informality in a bid.

DATE: January 12, 2022

Spec. No. 2020-14

Advertised: January 13, 2022



**Procurement Services Department**

P.O. Box 120488

San Diego, CA 92112-0488

(619) 686-6392

**NOTICE INVITING BIDS**

Notice is hereby given that the Procurement Services Department, General Services Building, First Floor, of the Port of San Diego (Port) will receive electronic bids at 1400 Tidelands Avenue, National City, California, until **2:00 P.M.** on the **22<sup>nd</sup>** day of **February, 2022** for:

**Specification No. 2020-15 – Drawing No. EM-2020-03**

**STRUCTURAL PILE REPAIRS TO NAVY PIER  
SAN DIEGO, CALIFORNIA**

**SCOPE OF WORK:**

The Contractor shall provide all equipment, supervision, management, labor, materials and systems necessary to perform the following work:

- Pier mark out, dive survey and other preconstruction surveys, including calculations of under deck repair quantities and form lengths.
- Full length encasement of 20-inch square concrete piles designated to be installed from EL. 8.5 to minimum 2 feet embedment below seabed including pile cleaning, excavation, backfill, forming, grouting, inspection and testing (257 piles, approximately 6300 linear feet of form).
- Remove and dispose of pipe debris and relocate and reinstall rock at locations on underwater slope where interferes with pile encasement (35 piles)
- Repair concrete at beams, pile caps, pile tops, soffit, low caps, and retaining walls including removal of unsound concrete, replace reinforcing steel when required, forming and placement of repair material, inspection and testing (695 areas, approximately 2200 cubic feet)
- Epoxy-inject repair of miscellaneous cracks found during preconstruction survey at beams, pile caps, pile tops, soffit, low caps, and retaining walls (approximately 500 linear feet).

**CONTRACTOR RELEVANT EXPERIENCE:**

Supply and installation of the pile encapsulation system is limited to Contractors and Manufacturers with proven experience and shall meet the following minimum requirements:

- The Contractor shall have a minimum of 5 years of experience in pile repair and installation of pile encapsulation systems.



- The Contractor shall have experience with a minimum of two projects using the proposed pile encapsulation system within the past 5 years, with at least two projects of similar complexity to this project.
- Demonstrate availability of experienced installation personnel from the Contractor dedicated to this Work. Provide a foreman with a minimum of five years of experience in the installation of the pile encapsulation system, who have supervised the installation of at least three projects using the pile encapsulation system, with at least one project of similar complexity to this project.

The total contract duration is **540 calendar days**. The Engineer's Construction estimate for this work is **\$11,200,000.00**.

The bidder must possess a valid California State Contractors License **Classification A, "General Engineering Contractor"**, at the time the contract is submitted.

Bids will be opened in public at or about that hour at 1400 Tidelands Avenue, National City, California, all as more particularly contained in **Document No. 73442** on file in the Office of the District Clerk of the Port. No Bidder may withdraw a bid after the date set for bid opening.

Plans and specifications are available for download on the Port of San Diego website, <https://pbsystem.planetbids.com/portal/13982/bo/bo-search>. For assistance in downloading these documents feel free to contact the Procurement Services Department at 619-686-6392.

Bidders must register as a vendor at the following website in order to download specification, Bid Proposal Package, plans, and prospective bidders list, and to receive addendums and notifications when issued.

<https://pbsystem.planetbids.com/portal/13982/portal-home>

Bidder shall submit their original Bid Proposal Package to the Procurement Services Department, 1400 Tidelands Avenue, National City, California 91950 within the date stated on the Contract Documents page after electronic bidding (See Section 4.0, Instruction to Bidders).

A **pre-bid conference** will be conducted at **2:00 p.m.** on **January 20, 2022 VIRTUALLY ONLY**. **This meeting can be accessed by dialing 619-535-7686, and use Conference ID: 647 548 245# or by using the following link: [Click here to join the meeting](#)** (see eBid system for URL, if needed). The Port's representative will be present at the pre-bid conference. **No questions will be allowed during the pre-bid conference.**

**Site Visit.** A site visit will be arranged for interested parties. **Those interested must RSVP** for site visit by using the following link: <https://forms.office.com/r/1tTvURjr16> **no later than January 25, 2022 at 10:00 a.m.** Due to capacity restrictions for the site visit, a maximum of two (2) representatives from each company may attend a site visit. After receiving all RSVP's, Port staff will make arrangements for site visit with individuals on

the RSVP list. Regarding COVID regulations: If you are not fully vaccinated we ask that face coverings are worn in areas that social distance can not be maintained, which would include this Site Visit.

Attendance at a site visit is not mandatory, however, all prospective Proposers are encouraged to attend. Submission of a Bid Proposal Package shall be evidence that the bidder has visited the jobsite and is satisfied with the conditions to be encountered if awarded the contract.

**Questions or comments** regarding this specification must be submitted electronically to our eBid system where the specification was downloaded and must be received by the Port no later than **February 8, 2022 at 2:00 p.m.** Questions received after the date stated here will not be accepted. Emails and faxes will not be accepted. Responses from the Port will be communicated via the electronic eBid system to all recipients of this specification.

In accordance with the provisions of the California State Labor Code, the Port has obtained the general prevailing rate of wages (which rate includes employer payments for health and welfare, vacation, pension and similar purposes) applicable to the work to be done, for straight time, overtime, Saturday, Sunday and holiday work. All labor employed on this project shall be paid no less than such minimum rates of wages. These wage rates are available for inspection at the office of the Procurement Services Department of the Port of San Diego.

It is the policy of the Port of San Diego that certified Small Business Enterprises (SBEs) shall have the maximum opportunity to participate in the performance of District Contracts. The SBE participation goal for this proposal/bid/quote is **5% (five percent)**. Certified SBEs with qualifying experience are encouraged to respond to the request for proposals/bids/quotes, etc.

Award of the contract, if made, will be within 120 calendar days after bid opening date. A bid guarantee in accordance with Subsection 5.6.2 of the General Condition is required with submission of a bid. No Bidder may withdraw a bid after the date set for bid opening.

Bidder shall file the bonds as required by the Contract and Civil Code section 9554. The provisions of Public Contract Code section 22300 apply to this Contract.

Bidders are hereby notified that the successful Bidder will be required to provide insurance in accordance with Subsection 5.6.1, "Contractor's Insurance," of the Section 5.0, General Condition.

A Notification Regarding Environmental Conditions has been included as Exhibit A in the project specifications. This notification will serve as the District's disclosure regarding potential hazardous materials that may be encountered during grading, excavation, trenching, and/or other ground penetration.

In the public interest, the Port reserves the right to reject any or all bids, or to waive any informality in a bid.

DATE: January 13, 2022

Spec. No. 2020-15

Advertised: January 13, 2022

**SECTION 2**

**OF THESE SPECIFICATIONS**

**CAN BE FOUND IN THE**

**BID PROPOSAL PACKAGE**



**A copy of this package must be attached  
to the electronic bid**

## **BID PROPOSAL PACKAGE**

**SPECIFICATION NO. 2020-15**

**STRUCTURAL PILE REPAIRS TO NAVY PIER  
SAN DIEGO, CALIFORNIA**

**BID DEADLINE:  
February 22, 2022 BY 2:00 p.m.**

Please Print Clearly

Business Name: \_\_\_\_\_

Address: \_\_\_\_\_

Authorized Rep. \_\_\_\_\_

**NOTE: BIDDERS ARE TO COMPLETE AND ATTACH THE DOCUMENTS CONTAINED IN THIS BID PROPOSAL PACKAGE AS INSTRUCTED IN SECTION 2.0 OF THIS PACKAGE, AND SUBMIT THE COMPLETED BID PROPOSAL PACKAGE IN ITS ENTIRETY ELECTRONICALLY PRIOR TO THE BID DEADLINE. BIDDER IS REQUIRED TO SUBMIT THE ORIGINAL BID PROPOSAL PACKAGE WITHIN THE TIME STATED ON THE CONTRACT DOCUMENTS COVER PAGE. (SEE INSTRUCTIONS TO BIDDERS, SECTION 4, ARTICLE 4.1)**

## SECTION 2.0 – BID FORMS

The following forms should be filled out and returned to the District in the Bid Proposal Package. A copy of the required forms shall accompany the electronic bid; the original Bid Proposal Package must be submitted within the time stated on the Contract Documents cover page.

1. Proposal
2. Contractor's License Information/Status
3. Noncollusion Affidavit\*
4. **Bid Schedule\*\***
5. **Subcontractor Listing Information\*\***
6. Bidder's Statement of Experience
7. Questionnaire for Bidder's Statement of Experience
8. Bidder's Certificate of Worker's Compensation
9. False Claims Certification
10. Respondent's Certificate of Compliance with Americans with Disabilities Act
11. SBE Sub-Participation Form
12. SBE Sub-Participation Acknowledgement Form
13. Bid Bond (Form supplied by Contractor's Surety)\*\*\*

### ASTERISK NOTES:

- \* Form must be subscribed and sworn to before Notary Public or other Officer.
- \*\* **These forms will be filled out electronically only.**
- \*\*\* The signature of the Surety must be acknowledged by a Notary.

### **PLEASE NOTE:**

These forms are designed to contain essential information concerning the Bidder and the bid, and must be legible. If any of the completed forms are illegible, the District, at its option may declare the entire bid unresponsive.

In the case of a discrepancy between the electronic bid and the original Bid Proposal Package, the electronic bid will be the accepted bid.

**P R O P O S A L**

San Diego, California

To the San Diego Unified Port District:

Pursuant to the "Notice Inviting Bids," specifications, instructions to Bidders, requirements on file with the Clerk, all affirmations and certifications in the Bid Proposal Package, the Proposal, and subject to all provisions of the Ordinances of the San Diego Unified Port District and applicable laws and regulations of the United States and the State of California, the undersigned hereby proposes to furnish to the San Diego Unified Port District, complete at the stated prices the referenced items or services.

**IF A SOLE OWNER OR SOLE CONTRACTOR, SIGN HERE:**

- (1) Name under which business is conducted \_\_\_\_\_
- (2) Signature (first and last name) of proprietor \_\_\_\_\_
- (3) Place of business \_\_\_\_\_  
   (Street and Number)  
 City and State \_\_\_\_\_
- (4) Telephone No. (\_\_\_\_) \_\_\_\_\_                      Zip Code \_\_\_\_\_
- (5) Fax \_\_\_\_\_                      E-Mail \_\_\_\_\_

**IF A PARTNERSHIP, SIGN HERE:**

- (1) Name under which business is conducted \_\_\_\_\_
- (2) Signature (first and last name) of each member of partnership:  
 (Indicate character of each partner – general or special.)

- (3) Place of business \_\_\_\_\_  
   (Street and Number)  
 City and State \_\_\_\_\_
- (4) Telephone No. (\_\_\_\_) \_\_\_\_\_                      Zip Code \_\_\_\_\_
- (5) Fax \_\_\_\_\_                      E-Mail \_\_\_\_\_

**IF A CORPORATION SIGN HERE:**

- (1) Name under which business is conducted \_\_\_\_\_
- (2) Signature with official title of officer  
Authorized to sign for the corporation \_\_\_\_\_
- (3) Incorporated under the laws of the State of \_\_\_\_\_
- (4) Place of business \_\_\_\_\_  
(Street and Number)  
City and State \_\_\_\_\_
- (5) Telephone No. (\_\_\_\_) \_\_\_\_\_ Zip Code \_\_\_\_\_  
Fax \_\_\_\_\_ E-Mail \_\_\_\_\_
- 

**IF A JOINT VENTURE, SIGN HERE:**

- (1) Name of the Joint Venture \_\_\_\_\_
- (2) Signature and official title of person authorized to sign on behalf of the Joint  
Venture \_\_\_\_\_
- (3) Place of Business \_\_\_\_\_  
(Street and Number)
- (4) Telephone No. (\_\_\_\_) \_\_\_\_\_ Zip Code \_\_\_\_\_  
Fax \_\_\_\_\_ E-Mail \_\_\_\_\_
- (5) Name of each entity (or person) comprising the joint venture and its state of  
incorporation, if applicable \_\_\_\_\_
- 

At the time this bid is submitted each entity (or person) comprising the Joint Venture has an effective State Contractor's License pursuant to California Business and Professions Code section 7028.15 and California Public Contract Code section 20123.5.



### CONTRACTOR'S LICENSE INFORMATION/STATUS

MY/OUR STATE CONTRACTOR'S LICENSE FOR \_\_\_\_\_  
CLASSIFICATION IS NO. \_\_\_\_\_, AND EXPIRES \_\_\_\_\_,  
20\_\_\_\_\_.

LICENSE HELD IN NAME OF \_\_\_\_\_

---

MY/OUR STATE CONTRACTOR'S LICENSE FOR \_\_\_\_\_  
CLASSIFICATION IS NO. \_\_\_\_\_, AND EXPIRES \_\_\_\_\_,  
20\_\_\_\_\_.

---

MY/OUR STATE CONTRACTOR'S LICENSE FOR \_\_\_\_\_  
CLASSIFICATION IS NO. \_\_\_\_\_, AND EXPIRES \_\_\_\_\_,  
20\_\_\_\_\_.

**NOTE: CALIFORNIA BUSINESS AND PROFESSIONS CODE SECTION 7028.15 PROVIDES THAT EXCEPT AS SPECIFIED THEREIN, THE BID OF A CONTRACTOR WHO IS NOT PROPERLY LICENSED AT THE TIME THE CONTRACTOR SUBMITTED THE BID SHALL BE CONSIDERED NONRESPONSIVE AND SHALL BE REJECTED. SAID CODE SECTION ALSO MAKES IT A MISDEMEANOR TO SUBMIT A BID ON THIS CONTRACT WITHOUT HAVING A PROPER LICENSE.**

**NONCOLLUSION AFFIDAVIT TO BE EXECUTED BY BIDDER AND SUBMITTED WITH BID**

State of: \_\_\_\_\_ )  
 ) ss.  
County of: \_\_\_\_\_ )

\_\_\_\_\_, being first duly sworn, deposes and says that he or she is \_\_\_\_\_ (title) of \_\_\_\_\_ (name of Bidder)

\_\_\_\_\_, the party making the foregoing bid that the bid is not made in the interest of, or on behalf of, any undisclosed person, partnership, company, association, organization or corporation; that the bid is genuine and not collusive or a sham; that the Bidder has not directly or indirectly induced or solicited any other Bidder to put in a false or sham bid, and has not directly or indirectly colluded, conspired, connived, or agreed with any Bidder or anyone else to put in a sham bid, or that anyone shall refrain from bidding; that the Bidder has not in any manner, directly or indirectly, sought by agreement, communication, or conference with anyone to fix the bid price of the Bidder or any other Bidder, or to fix any overhead, profit, or cost element of the bid price, or of that of any other Bidder, or to secure any advantage against the public body awarding the Contract of anyone interested in the proposed Contract; that all statements contained in the bid are true; and, further, that the Bidder has not, directly or indirectly, submitted his or her bid price or any breakdown thereof, or the contents thereof, or divulged information or data relative thereto, or paid, and will not pay, any fee to any corporation, partnership, company association, organization, bid depository, or to any member or agent thereof to effectuate a collusive or sham bid.

Dated: \_\_\_\_\_, 20\_\_\_\_\_.

\_\_\_\_\_  
Signature of Affiant

Subscribed and sworn to (or affirmed) before me on this \_\_\_\_\_ day of \_\_\_\_\_, 20\_\_, by \_\_\_\_\_, proved to me on the basis of satisfactory evidence to be the person(s) who appeared before me.

\_\_\_\_\_  
Notary Public in Signature

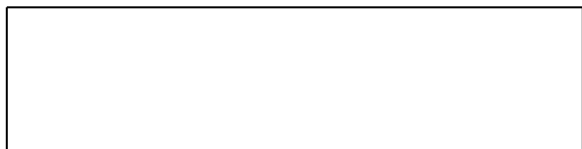

**NOTARY STAMP ENCLOSED**

## BID SCHEDULE

### FILL OUT THIS FORM ELECTRONICALLY ONLY

I/WE AGREE TO FURNISH ALL LABOR, EQUIPMENT AND MATERIALS AND PERFORM ALL THE WORK REQUIRED FOR **STRUCTURAL PILE REPAIRS TO NAVY PIER, SAN DIEGO, CALIFORNIA**, IN ACCORDANCE WITH THESE SPECIFICATIONS AND DRAWINGS PREPARED THEREFOR, FOR THE PRICES LISTED BELOW:

Item No.	Item	Unit of Measure	Estimated Quantity	Unit Price (In Figures)	Total (In Figures)
1	GENERAL CONSTRUCTION	LS	1	\$	\$
2	MOBILIZATION AND DEMOBILIZATION	LS	1	\$	\$
3	LONGSHOREMAN INSURANCE	LS	1	\$	\$
4	CONSTRUCTION BEST MANAGEMENT PRACTICES (BMP) PLANS	LS	1	\$	\$
5	PIER MARK OUT, DIVE AND OTHER PRECONSTRUCTION SURVEYS	LS	1	\$	\$
6	FULL LENGTH PILE ENCASEMENT AT 257 PILES	LF	6300	\$	\$
7	RELOCATE AND REINSTALL ROCK AT PILE BASES (35 PILES)	CF	2800	\$	\$
8	REMOVE AND DISPOSE OF UTILITY PIPE DEBRIS	LF	300	\$	\$
9	CONCRETE DEMOLITION	CF	2200	\$	\$
10	CONCRETE REPAIR	CF	2200	\$	\$
11	CRACK INJECTION	LF	500	\$	\$
12	STEEL REINFORCEMENT REPLACEMENT	LBS	2250	\$	\$
13	ALLOWANCE FOR RELATED WORK	AL	1	\$200,000	\$200,000
<b>TOTAL BID SCHEDULE:</b>					<b>\$</b>

#### NOTES:

THE PRICING SHOWN ABOVE SHALL REMAIN VALID FOR A PERIOD OF 120 CALENDAR DAYS FROM THE DATE OF THE BID OPENING.

Bids are to be submitted for the entire Work. The amount of the bid for comparison purposes will be the total of all items. The bidder shall set forth for each unit basis item of work a unit price and a total for the item, and for each lump sum item a total for the item, all in the electronic bid system.

The Contract prices paid for the work shall include full compensation for all taxes which the Contractor is required to pay, whether imposed by federal, state, or local government, including, without being limited to, federal excise tax. No tax exemption certificate nor any document designed to exempt the Contractor from payment of any tax will be furnished to the Contractor by the District, as to any tax on labor, services, materials, transportation, or any other items furnished pursuant to the Contract.

The San Diego Unified Port District retains the right to award on the basis of bids received or to reject any or all bids.

No conditional proposals will be accepted.

**\*\*\*END OF BID SCHEDULE\*\*\***

**SUBCONTRACTOR LISTING INFORMATION**

**FILL OUT THIS FORM ELECTRONICALLY ONLY**

Note: List the following information for **all** subcontractors who are required to be listed by the Subletting and Subcontracting Fair Practices Act, Section 4100, et seq., California Public Contract Code. (Also see Paragraphs 4.1.6 and 5.4.1) For each subcontractor listed, you must include all required information.

NAME	LICENSE NUMBER	LOCATION (Address, City, State)	PORTION OF WORK (Description)
------	-------------------	------------------------------------	----------------------------------

---

---

---

---

---

---

---

---

---

---

---

---

---

---

---

---

---

---

---

---

---

*FILL OUT ELECTRONICALLY ONLY*

## **BIDDER'S STATEMENT OF EXPERIENCE**

The Bidder is required to list work of similar character to that included in the proposed Contract, that such work has been successfully performed, and provide references which will enable the San Diego Unified Port District to judge its trustworthiness, as well as quality, fitness, capacity, and experience to satisfactorily perform the Contract. For the purposes of this Bid, a project is of similar character if it includes concrete repairs and pile encasements using the proposed pile encapsulation system within the past 5 years, with at least two projects of similar complexity to this project. Additionally, Bidder must have a minimum of 5 years of experience in pile repair and installation of pile encapsulation systems. Bidder is responsible for providing accurate and complete information.

List at least two (2) projects as part of the Bid Proposal Package Bidder's Statement of Experience. For each project, include the following information:

- Project Title
- Name of Agency/Company
- Point of Contact Name, Phone #, E-Mail Address
- Contract Amount
- Project Start Date
- Project Completion Date
- A description of Work Performed sufficiently detailed to demonstrate it is of similar character to the Project being bid, as described above.

**ATTACH ADDITIONAL SHEETS AS NECESSARY**

## QUESTIONNAIRE FOR BIDDER'S STATEMENT OF EXPERIENCE

**PLEASE TAKE NOTICE: ANSWERING ANY OF THE FOLLOWING QUESTIONS IN THE POSITIVE MAY CONSTITUTE EVIDENCE REFLECTING UPON THE BIDDER'S RESPONSIBILITY.**

1. Within the past five years, has a contract awarded to you or entered into by you, the Bidder, ever been terminated for default?

If so, please list the contract, the awarding public agency and/or contracting party other than Bidder by name, address and telephone number, the type of project, the reason for termination, and the contact person at the awarding public agency and/or contracting party.

2. Within the past five years, have you, the Bidder, filed legal action against an awarding public agency and/or contracting party?

If so, please list the contract, the awarding public agency and/or contracting party other than Bidder by name, address and telephone number, the type of project, the reason for filing suit and the contact person at the awarding public agency and/or contracting party.

3. Within the past five years, have you, the Bidder, been found to have filed a false claim in violation of California Government Code sections 12650, et seq.?

If so, please list the contract, the awarding public agency and/or contracting party other than Bidder by name, address and telephone number, the type of project, the name of the lawsuit including the court and the case number, if any, and the contact person at the awarding public agency and/or contracting party.

4. Within the past five years, have you been debarred or otherwise forbidden from bidding and/or being awarded construction work by any public or private entity?

If so, please list the contract, the awarding public agency and/or contracting party other than Bidder by name, address and telephone number, the type of project, the reason for debarment and the contact person at the awarding public agency and/or contracting party.

5. Have you ever been debarred from bidding or being awarded construction work by the Labor Commissioner?

If so, please state the reason for debarment, the date of debarment and the contact person at the Labor Commission.

**IF YOUR ANSWER TO QUESTION 5 IS YES, THE DISTRICT SHALL NOT PERMIT YOU TO BID, WORK OR BE AWARDED THIS OR ANY OTHER DISTRICT CONTRACT. FAILURE TO RESPOND TO THESE QUESTIONS MAY BE CONSIDERED A NON-RESPONSIVE BID SUBJECT TO REJECTION.**



## BIDDER'S CERTIFICATE OF WORKERS' COMPENSATION

NOTE: Bidder is required to complete the following certificate in accordance with California Labor Code section 1861.

I am aware of the provisions of Section 3700 of the California Labor Code which requires every employer to be insured against liability for workers' compensation or to undertake self-insurance in accordance with the provisions of that code, and I will comply with such provisions and furnish a workers compensation insurance certificate to the District before commencing the performance of the work of this Contract and as required by the Contract.

The Experience Modification Rating for the undersigned Bidder is \_\_\_\_\_.

\_\_\_\_\_  
Contractor

By: \_\_\_\_\_

Title: \_\_\_\_\_

Date: \_\_\_\_\_

## FALSE CLAIMS CERTIFICATION

The Certification below shall be signed by the Bidder and submitted with its bid:

BIDDER'S CERTIFICATION OF COMPLIANCE  
WITH  
LAWS RELATING TO  
FALSE CLAIMS

I hereby certify that I am aware of and fully understand the False Claims Act, California Government Code sections 12650, et seq. I further hereby certify that if awarded the Contract of which this certificate shall be made a part of, I will not violate any provisions of the False Claims Act or any other applicable federal or state laws and regulations relating to the filing of false claims against a public agency, including laws and regulations hereinafter enacted. I additionally certify that in the event it is determined that I have violated the False Claims Act that such violation shall be grounds for, among other things, debarment pursuant to San Diego Unified Port District Article 9.0, Ordinance 1980 and termination of this contract.

\_\_\_\_\_  
Contractor

By: \_\_\_\_\_

Title: \_\_\_\_\_

Date: \_\_\_\_\_

I.R.S. I.D. No.: \_\_\_\_\_

**RESPONDENT'S CERTIFICATE OF COMPLIANCE WITH AMERICANS WITH  
DISABILITIES ACT (ADA)**

**NOTE:** Respondent is required to complete the following certificate acknowledging its requirement to comply with the Americans with Disabilities Act and to require the same for any and all sub participants on this project.

I am aware of the provisions of the Americans with Disabilities Act, which ensures nondiscrimination and access to programs, services and activities without regard to disabilities, and I will comply with such requirements under the performance of the work of this Contract and as required by the Contract.

I also acknowledge that I and any subcontractors shall be individually responsible for our individual ADA programs.

\_\_\_\_\_  
Contractor

By: \_\_\_\_\_

Title: \_\_\_\_\_

Date: \_\_\_\_\_

## SBE SUB-PARTICIPATION FORM

<b>Project Number:</b>
<b>Project Description</b>

Submitted By: \_\_\_\_\_

**COMPANY NAME/CONTACT PERSON**

Company Information (Please print)	Certified SBE (Yes/No)	Check Appropriate Category	Work Subcontracted	Total Contract \$ Amount	Percentage of Total Contract
Company		<input type="radio"/> 1 <sup>st</sup> Tier Subcontractor		\$	%
Contact		<input type="radio"/> 2 <sup>nd</sup> Tier Subcontractor			
Address		<input type="radio"/> ___ Tier Subcontractor			
City/State/ Zip		<input type="radio"/> Material Supplier			
Phone/Fax		<input type="radio"/> Trucker			
Email		<b>To:</b>			
Company					
Contact	<input type="radio"/> 2 <sup>nd</sup> Tier Subcontractor				
Address	<input type="radio"/> ___ Tier Subcontractor				
City/State/ Zip	<input type="radio"/> Material Supplier				
Phone/Fax	<input type="radio"/> Trucker				
Email	<b>To:</b>				
Company			<input type="radio"/> 1 <sup>st</sup> Tier Subcontractor		\$
Contact		<input type="radio"/> 2 <sup>nd</sup> Tier Subcontractor			
Address		<input type="radio"/> ___ Tier Subcontractor			
City/State/ Zip		<input type="radio"/> Material Supplier			
Phone/Fax		<input type="radio"/> Trucker			
Email		<b>To:</b>			
Company			<input type="radio"/> 1 <sup>st</sup> Tier Subcontractor		
Contact	<input type="radio"/> 2 <sup>nd</sup> Tier Subcontractor				
Address	<input type="radio"/> ___ Tier Subcontractor				
City/State/ Zip	<input type="radio"/> Material Supplier				
Phone/Fax	<input type="radio"/> Trucker				
Email	<b>To:</b>				

**PLEASE FILL IN ALL SUB CONTRATORS AND THE PERCENTAGE (%) OF SUBCONTRACTED WORK  
SUBMIT THIS FORM WITH THE ORIGINAL BID PROPOSAL PACKAGE (SEE CONTRACT DOCUMENTS COVER PAGE)**

## SBE Sub-Participation Acknowledgement Form

Respondent acknowledges by signing this form that it is required to complete the SBE Sub-Participation Form acknowledging their good faith effort towards SBE Sub-Participation and/or meet the goal as the prime contractor as a certified SBE (if goal is established).

In the event of a discrepancy between form and totals entered on the eBid system, the District reserves the right to evaluate and waive any informalities.

\_\_\_\_\_  
Contractor

By: \_\_\_\_\_

Title: \_\_\_\_\_

Date: \_\_\_\_\_

**SECTION 3.0 – CONTRACT FORMS**

1. **Contract**
2. **Faithful Performance Bond and Labor and Materialmen’s Bond\***

**\*The Principal and Surety signatures on the Faithful Performance Bond and Labor and Materialmen’s Bond MUST be notarized. An “All Purpose Acknowledgement Form for both signature must accompany the contract.**

**Return ALL Contract Forms To:**

**Procurement Services Department  
1400 Tidelands Avenue  
National City, CA 91950  
619-686-6392**

**PLEASE NOTE:**

**It is not necessary to complete these forms to bid on this project. But in the event Bidders is awarded the Contract he/she shall be required to execute all Contract Forms.**

## CONTRACT

At San Diego, California, this \_\_\_\_\_ day of \_\_\_\_\_, 20\_\_\_\_, the SAN DIEGO UNIFIED PORT DISTRICT, a public corporation in the County of San Diego, State of California ("District") and \_\_\_\_\_ ("Contractor") hereby agree:

1. This Contract includes the attached Notice Inviting Bids, Bid Proposal Package, Bid Schedule (Base Bid and Additive Bid Schedule \_\_\_ plus \_\_\_ only), Bonds, Instructions to Bidders, General Conditions, Technical Specifications, Drawings and Addenda, if any, and the Plans, Specifications, Technical Specifications and drawings filed with the District Clerk as Document No. \_\_\_\_\_, and such other incorporated writings, all of which are by this reference incorporated herein and made a part hereof.

2. Contractor shall perform and be bound by all of the terms and conditions of this Contract, shall perform the work in strict conformity with the Contract and shall perform and complete the work in a good and workmanlike manner.

3. In the absence of damages incurred by the District, the District's legal inability to pay based on legally asserted claims of third parties, and/or the District's exercise of its rights of offset, District shall pay to Contractor the prices set forth in the attached Bid Schedule at the times and in the manner and with such additions or deductions as are provided for in this Contract and Contractor shall accept such payment in full satisfaction of all claims incident to such performance.

4. No Board Member, officer or employee of the District shall be liable for any portion of the Contract price or for any of the work performed by Contractor under this Contract and it is further understood and agreed that the District's liability is limited and confined as imposed by law.

5. This Contract is executed and entered into in the County of San Diego, State of California, and the obligations under this Contract are incurred and shall be performed and executed in said County.

6. Contractor shall commence work as required by the Contract, shall prosecute the work diligently, and shall complete it within the time limit fixed in the specifications. Time is of the essence of this Contract.

SAN DIEGO UNIFIED PORT DISTRICT

By: \_\_\_\_\_  
Director's Name  
Director's Title

CONTRACTOR'S NAME  
Contractor

License No.: \_\_\_\_\_

Approved as to form and legality:  
DEPUTY GENERAL COUNSEL

By: \_\_\_\_\_  
Signature

Its \_\_\_\_\_  
(Type or print Signatory's  
name and title)

\_\_\_\_\_  
By: Assistant/Deputy

**Contractors are required by law to be licensed and regulated by the Contractor's State License Board which has jurisdiction to investigate complaints against Contractors if a complaint regarding a patent act or omission is filed within four years of the date of the alleged violation. A complaint regarding a latent act or omission pertaining to structural defects must be filed within 10 years of the date of the alleged violation. Any questions concerning a Contractor may be referred to the Registrar, Contractor's State License Board, P.O. Box 26000, Sacramento, California 95826.**

This document may be signed by the District electronically, including but not limited to via DocuSign. Manually and/or electronically signed counterparts shall together be deemed one complete document.



**FAITHFUL PERFORMANCE BOND AND LABOR AND MATERIALMEN'S BOND**

\_\_\_\_\_ as Principal, and \_\_\_\_\_, a corporation authorized to do business in the State of California and organized and existing under and by virtue of the laws of the State of \_\_\_\_\_, and presently possessed of authority under Title 31 of the United States Code to do business under Sections 9304 to 9308 thereof and authorized to transact business as a surety in California, as Surety, are held and firmly bound unto the San Diego Unified Port District, a public corporation in the County of San Diego, State of California, in the sum of \_\_\_\_\_ Dollars (\$ \_\_\_\_\_), for the faithful performance of a certain Contract hereinafter referred to, and in the like sum of \_\_\_\_\_ Dollars (\$ \_\_\_\_\_), for the benefit of laborers and materialmen hereinafter designated, to be paid to the San Diego Unified Port District, for the payment of which well and truly to be made, the said Principal and the said Surety, hereby bind themselves and all singularly, their heirs, administrators, executors, successors and assigns, jointly and severally.

Any payment made hereunder shall be made in the County of San Diego, State of California.

Said Principal has entered into the annexed Contract with the San Diego Unified Port District to perform and complete said Contract in strict conformity therewith in a good and workmanlike manner.

The conditions of the above and foregoing obligations are such that:

If the said Principal shall faithfully perform the said Contract, then the above obligation with respect to the faithful performance of said Contract shall be void, otherwise to remain in full force and effect; and

If said Principal or his subcontractors, their heirs, executors, administrators, successors and assigns shall fail to pay for any materials or other supplies used in, upon, for or about the performance of the work Contracted to be done, or for any work or labor thereon of any kind or for amounts due under the Unemployment Insurance Code with respect to such work or labor, or for any amounts required to be deducted, withheld and paid over to the Employment Development Department from the wages of employees of the Contractor and his subcontractors pursuant to Section 13020 of the Unemployment Insurance Code, with respect to such work and labor, then said Surety will pay the same in or to an amount not exceeding the amount hereinabove specified to be for the benefit of laborers and materialmen and also will pay, in case suit is brought upon this bond, such reasonable attorney's fee as shall be fixed by the Court, awarded and taxed as provided by law.

This bond, to the extent of the obligation herewith with respect to laborers and materialmen, shall inure to the benefit of any and all persons, companies and

corporations entitled to file claims on a public works contract under Division Third, Part 4, Title 15, of the Civil Code of the State of California, so as to give a right of action to them or their assigns in any suit brought upon this bond.

And that said Surety, for value received, hereby stipulates and agrees that no change, extension of time, alteration or addition to the terms of the Contract or to the work to be performed thereunder or the specifications accompanying the same, shall in any way affect its obligations on this bond, and it does hereby waive notice of any such change, extension of time, alteration or addition to the terms of the Contract or to the work or to the specifications. Said Surety agrees to be fully bound by and participate in any dispute resolution requirements of this Contract. Surety will act within fifteen (15) days after receipt of a written demand pursuant to the Labor and Material Bond and/or Performance Bond by Obligee herein.

DATED: \_\_\_\_\_, 20\_\_\_\_\_.

\_\_\_\_\_  
Principal

By: \_\_\_\_\_

\_\_\_\_\_  
Surety

By: \_\_\_\_\_

Attorney in Fact

\_\_\_\_\_  
Mailing Address

\_\_\_\_\_  
City State Zip

APPROVED AS TO FORM AND LEGALITY

\_\_\_\_\_  
Deputy General Counsel

**(NOTE: BOTH SIGNATURES (PRINCIPAL AND ATTORNEY IN FACT) ON THIS PAGE MUST BE NOTARIZED WITH AN ALL PURPOSE ACKNOWLEDGEMENT FORM)**

This document may be signed by the District electronically, including but not limited to via DocuSign. Manually and/or electronically signed counterparts shall together be deemed one complete document.

## SECTION 4.0 – INSTRUCTION TO BIDDERS

### ARTICLE 4.1 – PRE-BID OPENING INSTRUCTIONS

**4.1.1 ELECTRONIC PLANS AND SPECIFICATIONS.** Plans and specifications may be obtained by visiting the District's website at <http://vendors.planetbids.com/sdupd/quicksearch.cfm?stage=bidding>. Prime Bidders are advised that proposed subcontractors should obtain their own sets of plans and specifications from the District website, so that they will be placed on the District's email list for addenda. The District will not be responsible for sending addenda to any person not listed on prospective bidder list.

### 4.1.2 EXAMINATION OF PLANS, SPECIFICATIONS AND WORK SITE

**4.1.2.1** The Bidder is required to examine carefully the site of the work, the proposal, all plans and specifications. The Bidder shall fully satisfy itself as to the character, quality and quantities of work to be performed, materials to be furnished and as to the requirements of the Contract, including the General and Supplementary Requirements and Technical Specifications. The Bidder shall familiarize itself with all local laws, ordinances, rules and requests that may affect the work or the performance of the work.

**4.1.2.2** Any information shown on the plans as to the soil or material borings or tests or existing materials is solely for the purpose of design. The information is not guaranteed, and no claims for extra work or damages will be considered if it is found during construction that the actual soil or material conditions vary from those indicated. The Contract documents show subsurface conditions or otherwise hidden conditions as they are supposed or believed by the District and/or its agents to exist; but it is not intended or to be inferred that the conditions shown thereon constitute a representation that such conditions are actually existent. Except as otherwise specifically provided in the Contract documents or as agreed, the District and its agents shall not be liable for any loss sustained by the Contractor or its agents or subcontractors as a result of any variance of such conditions as shown on the plans and the actual conditions revealed during the progress of the work or otherwise.

**4.1.2.3** Where the District or its agents have made investigations of subsurface conditions in areas where the work is to be performed, such

investigations were made only for the purpose of study and design. The conditions indicated by such investigations apply only at the specific location of each boring or excavation at the time the borings or excavations were made. Where such investigations have been made, bidders, or Contractors may inspect the records at the Engineer's office as to such investigations subject to and upon the conditions set forth below.

**4.1.2.3.1** The records of such investigations are not a part of the Contract and are shown solely for the convenience of the bidder or contractor. It is expressly understood and agreed that (a) the District and its agents assume no responsibility whatsoever with respect to the sufficiency or accuracy of the investigations or records or the accuracy of the interpretations set forth therein or made by the District or its agents in their use; (b) represents only the opinion of the District or its agents as to the character of the materials encountered by them in the test borings; and (c) there is no warranty or guarantee, either express or implied, that (1) the conditions indicated by such investigations or records are representative of those existing throughout such areas, or any part, or (2) that unlooked-for developments may not occur, or (3) that materials other than, or in proportions, densities, or other characteristics different from, those indicated may not be encountered.

**4.1.2.3.2** The availability or use of information described in this provision is not to be construed in any way as a waiver of the bidder's responsibility to examine the site and the Contract documents and a bidder is cautioned to make such independent investigations and examination as it deems necessary to satisfy itself as to conditions to be encountered in the performance of the work.

**4.1.2.3.3** No information derived from such inspection of records of investigations or compilation thereof made by the District or its agents will in any way relieve the bidder from any risk or from properly fulfilling the terms of the Contract nor entitle the Contractor to any additional compensation.

**4.1.2.4** The Bidder represents it has studied all surveys and investigation reports about subsurface and latent physical conditions pertaining to the job site, that it has performed such additional surveys and investigations as it deems necessary to complete the work at the bid price and that it has correlated the results of

all such data with the requirements of the Contract documents. The submission of the Bid Proposal Package shall be prima facie evidence that the Bidder has made such an examination and is satisfied as to the conditions encountered, including locality, uncertainty of weather and all other contingencies and as to the character, quality, quantity and scope of the work. No allowance shall subsequently be made on behalf of the Contractor on account of an error on its part, its negligence, or its failure to acquaint itself with the conditions of the work site.

#### **4.1.3 INTERPRETATION OF DRAWINGS AND DOCUMENTS**

**4.1.3.1** If any Bidder, prior to submitting bids, should find discrepancies in, or omission from the drawings, specifications or other proposed Contract documents, or if it should be in doubt as to the true meaning of any part of the proposed Contract documents, it SHALL at once make a written request to the Engineer for correction, clarification or interpretation of the point or points in question. The person submitting such request shall be responsible for its prompt delivery. A Contractor waives its right, if any, for additional compensation if it fails to seek correction, clarification or interpretation prior to submittal of a Bidder's bid.

**4.1.3.2** In the event that the Engineer receives such a request, and it should be found that certain essential information is not clearly and fully set forth, or if the Engineer discovers or is informed of errors, omission or points requiring clarification in the drawings or documents, a written addendum will be emailed to each person to whom downloads a set of Contract documents has been delivered. The District will not be responsible for any instructions, explanations or interpretations of the documents presented to Bidders in any manner other than by written addendum.

**4.1.3.3** To the extent there is a lack of detail or information or conflict, the best or most for the District shall be required to be installed, and the Engineer shall be guided accordingly.

**4.1.4** ADDENDA. The effect of all addenda to the Contract documents shall be considered in the bid, and said addenda shall be made a part of the Contract documents and shall be returned with them at time of award. Before submitting its bid, each Bidder shall inform itself as to whether or not any addenda have been issued and

failure to cover in this bid any such addenda issued, may render its bid informal and result in its rejection.

**4.1.5** BIDDERS INTERESTED IN MORE THAN ONE BID. No person, firm or corporation shall be allowed to make, file or be interested in more than one bid for the same work unless alternate bids are called for. A person, firm or corporation who has submitted subproposal to a Bidder, or who has quoted prices on materials to a Bidder, is not hereby disqualified from submitting a subproposal or quoting prices to other Bidders or from submitting a bid in its own behalf.

#### **4.1.6 ELECTRONIC BIDDING**

**4.1.6.1** All Bidders are required to submit their bids electronically. The electronic bid system will close exactly at the date and time set forth in the Notice Inviting Bids or as changed by addenda. An electronic copy of the Bid Proposal Package and bid security (See 4.1.7.1.7) must accompany the electronic bid for the bid to be valid. Bidder shall be required to submit their Bid Schedule and Subcontractors List electronically.

**4.1.6.2** Bidders are responsible for submitting and having their bids accepted before the closing time set forth in the Notice Inviting Bids or as changed by addenda. NOTE: Pushing the submit button on the electronic bid system may not be instantaneous; it may take time for the Bidder's documents to upload and transmit before the bid is accepted. It is the Bidder's sole responsibility to ensure their documents are uploaded, transmitted, and arrive in time electronically. The District will have no responsibility for bids that do not arrive in a timely manner, no matter what the reason.

**4.1.6.3** The top three bidders will be required to submit their original Bid Proposal Package within the time stated on the Contract Documents cover page. Failure to do so may result in forfeiture of the Bidder's bid security and/or rejection of bid. The District reserves the right to request any other original Bid Proposal Packages.

**4.1.6.4** In the case of a discrepancy between the electronic bid and the original Bid Proposal Package, the electronic bid will be the accepted bid.

#### **4.1.7 PROPOSALS**

**4.1.7.1** Bids to receive consideration shall be made in accordance with the following instructions:

**4.1.7.1.1** Bidder will download: (a) a bound Bid Proposal Package, (b) the bound specifications, and (c) plans. The Bid Proposal Package submitted by the Bidder may sometimes be referred to herein as the “bid(s)” and/or the “proposal(s).”

**4.1.7.1.2** Bids may be made electronically and only upon the forms included in the Bid Proposal Package, which form a part of the Contract documents. Bid Proposal Package forms cannot be altered or modified. All bid items in the Bid Proposal Package should be properly and completely filled in electronically with a unit price or lump sum and totals. The signature of all persons signing shall be in longhand. Any document which is detached from the bound Bid Proposal Package documents or altered or modified or not properly completed, may render the bid non-responsive and may result in rejection of the bid. In addition to the documents contained in the Bid Proposal Package, no Contract documents shall be altered or modified.

**4.1.7.1.3** All notations in the bid must be in ink or typewritten. No erasures will be permitted. Mistakes may be crossed out and corrections typed or written in with ink adjacent thereto, and must be initialed in ink by the person or persons signing the bid.

**4.1.7.1.4** Bids shall not contain any recapitulation of the work to be done. Alternate or alternative proposals will not be considered unless called for. No oral, telegraphic or telephone proposals or modifications will be considered.

**4.1.7.1.5** The District reserves the right to consider the financial responsibility and general competency of each bidder, as well as its reputation within the industry, to determine if the apparent low bidder has the apparent ability to meet and complete successfully the requirements of the Contract. Upon request, the apparent low bidder shall provide a financial statement, audited if necessary, in addition to any other requested information.

**4.1.7.1.6** Each Bidder shall list its proposed subcontractors which are required to be listed by Public Contract Code section 4100, et seq. by

name, Contractor’s state license number, location and portion of work on the Subcontractor tab in the electronic system. (See also Subsection 5.4.1)

**4.1.7.1.7** Each Bidder must accompany its bid by a cashier’s check of the Bidder drawn upon some responsible bank, or a check of the Bidder drawn upon such bank properly certified, or an approved corporate surety bid bond payable to the San Diego Unified Port District, for a sum not less than ten (10) percent of the aggregate sum of the bid, which said check or bid bond and the moneys represented thereby shall be held by the District as security that the Bidder, if awarded the Contract, will in good faith enter into such Contract and furnish the required labor and materialmen’s bond and a faithful performance bond. Said corporate surety bid bond shall be from an admitted surety, as defined in Code of Civil Procedure Section 995.210, authorized to do business as such in the State of California, possess an AM Best Rating of VII or better, and be listed on the Federal Registry Circular 570. The Bidder, upon its failure or refusal to execute said Contract and give said labor and materialmen’s bond and a faithful performance bond required within fourteen (14) days as required by these documents, shall forfeit to the District as liquidated damages for such failure or refusal, such security deposited with its bid. Bidder will be required to submit a copy of their bid bond or acknowledge a cashier’s check or certified check when submitting their electronic bid. The original cashier’s check, certified check or approved bid bond must accompany the original Bid Proposal Package. An electronic bid or bid received and not accompanied by such cashier’s check, certified check or approved bid bond, may be rejected.

**4.1.7.1.8** A copy of the Bid Proposal Package shall be attached to the electronic bid on or before the day and hour set for the opening of bids. The original Bid Proposal Package shall be delivered to the District office as specified in the “Notice Inviting Bids,” and on the date and time indicated on the Contract Documents cover page. Failure to provide the original Bid Proposal Package may result in forfeiture of the Bidder’s bid security and/or rejection of bid.

**4.1.7.1.9** A Bidder may withdraw its bid personally or by a written request by an authorized representative prior to the Bid Opening. A Bidder may not withdraw its bid for 120 calendar days after the Bid Opening. A

Bidder considering withdrawing their bid should be familiar with the provisions of the Public Contract Code Sections 5100 to 5107 regarding relief of bidders. Bid bonds shall be returned within 60 days after award of this Contract.

## **ARTICLE 4.2 – BID OPENING**

### **4.2.1 OPENING OF BIDS**

**4.2.1.1** Bids will be opened electronically at the time and place set in the “Notice Inviting Bids” in the General Services & Procurement Building, National City, California. Bidders or their representatives, and other interested persons, are invited to be present at the opening of bids.

### **4.2.2 AWARD OR REJECTION OF BIDS.**

The Contract may be awarded to the lowest responsive and responsible Bidder under the schedule or schedules complying with these and with all other Contract documents. The District reserves the right to reject any or all bids, and to waive any informality or technicality in bids received and any requirements of these specifications as to bidding procedures.

### **4.2.3 BID PROTESTS**

**4.2.3.1 Time for filing.** Any protest must be submitted in writing to the Director/Chief, Procurement Services Department, Port of San Diego, 1400 Tidelands Avenue, National City, California 91950 before 5:00 p.m. of the 10<sup>th</sup> business day following bid opening.

#### **4.2.3.2 Form of protest:**

**4.2.3.2.1** The initial protest document shall contain a complete statement of the basis for the protest.

**4.2.3.2.2** The protest shall refer to the specific portion of the document that forms the basis for the protest.

**4.2.3.2.3** The protest shall include the name, address and telephone number of the person representing the protesting party.

**4.2.3.2.4** The party filing the protest shall concurrently transmit a copy of the initial protest document and any attached documentation to all other parties with a direct financial interest that may be adversely affected by the outcome of the protest. Such parties include all other Bidders or proposers who appear to have a reasonable

prospect of receiving an award depending upon the outcome of the protest.

**4.2.3.3** The Board of Port Commissioners will issue a decision on the protest. If the Board of Port Commissioners determines that a protest is frivolous, the party originating the protest may be determined to be irresponsible and that party may be determined to be ineligible for future Contract awards.

**4.2.3.4** The procedure and time limits set forth in this section are mandatory and are the Bidder’s sole remedy in the event of bid protest and failure to comply with these procedures shall constitute a waiver of any rights to further pursue the bid protest, including filing a Government Code claim or legal proceeding.

## **ARTICLE 4.3 – AWARD**

### **4.3.1 THE CONTRACT**

**4.3.1.1** The Bidder to whom award is made shall execute a written Contract with the San Diego Unified Port District and shall furnish the required Faithful Performance and Labor and Material bonds within fourteen (14) days after receipt of a form of Contract for execution, unless an extension of time is granted to the Bidder in writing. The Contract shall be made in the form adopted by the District. If the Bidder to whom the award is made fails to furnish said bonds and execute the Contract as required, the award may be annulled, and an award may be made to the next lowest responsible Bidder and such Bidder shall fulfill every Contract stipulation as if it were the party to whom the first award was made. A corporation to which an award is made shall furnish evidence of its corporate existence and evidence that the officer signing the Contract and bonds for the corporation is duly authorized to do so. After the District’s receipt of the executed Contract form and the bonds, and the Contractor’s original, executed Bid Proposal Package will be bound together with the remainder of the documents which form the Contract and documented with the District clerk, excluding the plans which will be documented with the District clerk but will not bound together with the remainder of the Contract documents.

**4.3.1.2** The surety supplying the surety bonds must be an admitted surety insurer, as defined in Code of Civil Procedure Section 995.120, authorized to do business as such in the State of California, have an AM Best Rating of VII or

more, and be listed on Federal Registry Circular 570.

## **ARTICLE 4.4 – NOTICE TO BIDDERS**

### **4.4.1 EMPLOYMENT OF APPRENTICES**

**4.4.1.1** Bidder is directed to the provisions in Sections 1777.5, 1777.6 and 1777.7 of the California Labor Code concerning the employment of apprentices by a Contractor and any subcontractor performing a public works Contract.

**4.4.1.1.1** Labor Code section 1777.5 requires the Contractor or subcontractor employing tradesmen in any apprenticeable occupation to apply to the joint apprenticeship committee in the area of the site of the public works project and which administers the apprenticeship program for a certificate of approval. Contractor or subcontractor shall not be required to submit individual applications for approval to local joint apprenticeship committees provided they are already covered by the local apprenticeship standards. The ratio of apprentices to journeymen and contributions to funds to administer apprenticeship programs shall be determined by Section 1777.5 and the responsibility for compliance with that section for all apprenticeable occupations shall be with the General Contractor.

**4.4.1.1.2** Labor Code section 1777.5 does not apply to Contracts of general contractors or to contracts of specialty contractors not bidding for work through a general or Prime Contractor, when the contracts of general contractors or those specialty contractors, involve less than Thirty Thousand Dollars (\$30,000.00) or twenty (20) working days. A contractor who willfully violates Labor Code section 1777.5 shall be denied the right to bid on or receive a public works contract for a period of up to one (1) year for the first violation, and for a period up to three (3) years for the second and subsequent violations, from the date the determination of noncompliance made by the Administrator of Apprenticeship becomes an order of the California Apprenticeship Council. Contractor shall also be subject to the payment of the civil penalty as provided in Labor Code section 1777.7. Interpretation and enforcement of said Sections 1777.5 and 1777.7 shall be in accordance with the rules and procedures of the California Apprenticeship Council.

**4.4.2 EQUAL EMPLOYMENT OPPORTUNITY AND NON-DISCRIMINATION CLAUSE.** It is the policy of the District that all contractors and lessees interested in conducting business with the District shall not discriminate against any employee or applicant for employment because of age (over 40), ancestry, color, disability (mental or physical), gender, marital status, medical condition, national origin, pregnancy, race, religion, sexual orientation, or veteran status, and shall take action to assure applicants are employed, and that employees are treated during employment, without regard to age (over 40), ancestry, color, disability (mental or physical), gender, marital status, medical condition, national origin, pregnancy, race, religion, sexual orientation, or veteran status.

**4.4.3 PUBLIC WORKS CONTRACTOR REGISTRATION PROGRAM** In accordance with the provisions of Labor Code section 1771.1. (a) A contractor or subcontractor shall not be qualified to bid on; be listed in a bid proposal, subject to the requirements of Section 4104 of the Public Contract Code, or engage in the performance of any contract for public work, as defined in this chapter, unless currently registered and qualified to perform public work pursuant to Section 1725.5. It is not a violation of this section for an unregistered contractor to submit a bid that is authorized by Section 7029.1 of the Business and Professions Code or by Section 10164 or 20103.5 of the Public Contract Code, provided the contractor is registered to perform public work pursuant to Section 1725.5 at the time the contract is awarded.

**4.4.3.1** No contractor or subcontractor may be listed on a bid proposal for a public works project (submitted on or after March 1, 2015) unless registered with the Department of Industrial Relations pursuant to Labor Code section 1725.5 [with limited exceptions from this requirement for bid purposes only under Labor Code section 1771.1(a)].

**4.4.3.2** No contractor or subcontractor may be awarded a contract for public work on a public works project (awarded on or after April 1, 2015) unless registered with the Department of Industrial Relations pursuant to Labor Code section 1725.5.

**4.4.3.3** This project is subject to compliance monitoring and enforcement by the Department of Industrial Relations.

**4.4.3.4** The Bidder and its Subcontractors, upon failure to comply with Section 4.4.3 above may be deemed non-responsive and bid may be rejected.

**\*\*\*END OF SECTION\*\*\***



## SECTION 5.0 – GENERAL CONDITIONS

### ARTICLE 5.1 – GENERAL PROVISIONS

#### 5.1.1 THE CONTRACT

**5.1.1.1** The Contract documents as defined form the Contract between the District and the Contractor. The Contract represents the entire integrated agreement between the parties and supersedes all prior negotiations, representations or agreements, either written or oral. The Contract may be amended or modified only as set forth in the Contract documents. The Contract documents shall not be construed to create a contractual relationship of any kind between the District and any other contractor or subcontractor or supplier of any tier other than the District and Contractor.

**5.1.1.2** The Contractor's signing of the Contract signifies its acceptance of the time of completion as being sufficient for completion of the Work, as well as acceptance of all of the other terms and conditions of the Contract documents.

**5.1.1.3** Contractor acknowledges that it has read every clause in the Agreement, these conditions and the specifications; has examined the location where the Work is to be done; and has made all inquiries and investigations necessary to enable it to understand thoroughly the intent of all parts of the Contract documents, and the nature of the Work; and agrees that it will not make any claim for compensation, extension of time or other allowance of any sort, based upon or arising out of any alleged misunderstanding by it of any part of the Contract documents.

#### 5.1.2 DEFINITION OF TERMS

**5.1.2.1** Whenever in these Contract documents the following terms are used, their intent and meaning are as follows:

**5.1.2.1.1** The word "allowance" means the allocation of funds for items in the bid schedule for the purpose of identification and budgeting of work where quantities and/or cost are unknown at the time of bidding. If the allowance is either greater or less than the allowance, the contract price shall be increased or decreased accordingly upon proof of the amount expended by the Contractor. Allowances shall include all of the costs of materials, fixtures, or equipment and all costs of delivery, handling, and installations. Contractor shall make no claim for

additional compensation because of any increase, decrease or elimination of any allowance item.

**5.1.2.1.2** The term "beneficial occupancy" shall mean the point in progress of the Work when the Project is Substantially Complete and the District, after notice, takes control of the entire Work as provided for herein.

**5.1.2.1.3** The word "Board" means the Board of Port Commissioners specified in the San Diego Unified Port District Act.

**5.1.2.1.4** The term "Change Order Request" is a written request for either a cost or time adjustment.

**5.1.2.1.5** The term "completion" shall mean the formal written acceptance of the Work by the District and the recordation of a Notice of Completion with the county recorder or, in the event formal acceptance does not occur, the recordation of a Notice of Cessation with the county recorder.

**5.1.2.1.6** The words "Contract" and "Contract document" mean everything contained in this bound volume and any and all other written instruments and drawings of every kind and nature which are attached to or made a part hereof by reference or by operation of law; such as, but not limited to, Notice Inviting Bids, Instructions to Bidders, Proposal, submitted Bid Proposal Package, Bonds, Addenda, Specifications (General), General Conditions, Supplementary Requirements, Technical Specifications, Drawings, the Agreement which is prepared for execution by the District and the Contractor, any and all supplemental written agreements, orders or addenda amending or extending the work contemplated and which may be required to complete the work in a substantial and acceptable manner. The Contract documents shall not include any other documents or agreements not listed in this section. However, the Contractor may be subject to standards and/or requirements set forth in other documents or agreements to which the Contractor is not a party. When such standards and/or requirements are referenced in the Contract documents and specifically made applicable to the Contractor, the same are hereby incorporated by reference as though fully set forth herein.

**5.1.2.1.7** The term “Contract Change Order” shall mean a written document prepared by the District (See Form 9, Appendix A) and signed by the District and/or the Contractor stating the agreement on one or all of the following: a significant change in the Work; an adjustment in the Contract sum, if any; and an adjustment in the Contract time, if any. All changes in the Work involving price and or time must be authorized by a Contract Change Order.

**5.1.2.1.8** The term “Contract Completion Date” shall mean the date for completion of the Work as determined by the Contract time and the Notice to Proceed Date.

**5.1.2.1.9** The word “Contractor” means the person, firm or corporation with whom the Contract is made by the District.

**5.1.2.1.10** The term “Contract Time” shall mean the Contract duration for the performance of the Work as specified by the Contract terms or as modified by a Contract Change Order.

**5.1.2.1.11** The word “District”, “Port” and “Port District” mean the San Diego Unified Port District, a public corporation of the State of California.

**5.1.2.1.12** The word “Engineer” means the designated employee of the San Diego Unified Port District, who shall be in charge of the work and who may be represented on the Work by engineers, assistants and inspectors who are authorized to act for him within the scope of the particular entrusted duties.

**5.1.2.1.13** The term “Executive Director” means the Executive Director of the San Diego Unified Port District, the chief administrative officer of the District.

**5.1.2.1.14** The word “Modification” shall mean any written Contract Change Order or supplemental written agreements or any other written and District approved modification to the Contract documents.

**5.1.2.1.15** The word “Plans” shall mean the drawings, profiles, cross-sections, working drawings and supplemental drawings, or reproductions thereof, approved by the Engineer, which show the location, character, dimensions or details of the Work and incorporate into the Contract.

**5.1.2.1.16** The terms “Request for Information” or “RFI” are written requests on the form provided by the District (see Form 2, “Request for Information,” Appendix A) from the Contractor to the District requesting information or clarification of the plans, specifications, drawings or Work which requires a written response from the District.

**5.1.2.1.17** The term “Request for Proposal” is a written request from the District to the Contractor describing a proposed change in the Work desired by the District and which requires a written response from the Contractor. The Contractor shall respond in the form of a Change Order Request.

**5.1.2.1.18** The term “Substantially Complete” shall mean when the Work is completed to a sufficient degree and quality, and in strict accordance with the Contract, so as to allow the total and complete use of the Work for all intended purposes. If the District is not able to use the Work for one or more of its intended purposes, no matter how small the purpose may be, the Work is not Substantially Complete.

**5.1.2.1.19** The words “Work” or “Project” mean everything required to be furnished or performed under the Contract documents as defined.

**5.1.2.1.20** The term “Work Site” shall mean the physical location of the Work as particularly identified in the Technical Specifications.

**5.1.2.1.21** The term “written direction” is a written direction from the Engineer or its authorized representative which may be in response to a Request for Information, bulletin (See Form 4, “Bulletin,” Appendix A) or any other written form from the District to the Contractor.

**5.1.3** INCORPORATION. Whenever a reference is made to any portion of this Contract or any other applicable law or ordinance, the reference applies to all existing and future amendments and additions.

#### **5.1.4** DIVISIONS OF PLANS AND SPECIFICATIONS

**5.1.4.1** All sections of the specification shall be read and interpreted as constituting a whole and not as an aggregation of individualized parts, and whatever is specified in one section shall be

construed as applying to all sections.

**5.1.4.2** The division of the specifications into a number of sections, articles or specifications is for convenience only, and no other construction or interpretations shall be made. In this respect, no section of the specifications is written for an individualized trade, occupation or profession.

**5.1.4.3** The specifications may consist, in part, of abbreviated or "streamlined" type and include incomplete sentences. Omissions of words or phrases such as "the Contractor shall," "in conformity therewith," "shall be," "as noted on the drawings," "according to the plans," "a," "an," "the," and "all" are intentional. Omitted words and phrases shall be supplied by inference in the same manner as they are when a "Note" occurs on drawings. Words "shall be," or "shall" will be supplied by inference where colon (:) is used within sentences or phrases.

#### **5.1.5 EFFECT OF PLANS AND SPECIFICATIONS**

**5.1.5.1** The plans, together with the attached specifications, will govern the Work to be done. Anything mentioned in these specifications and not shown on the plans and detailed drawings, or shown on the plans and detail drawings and not mentioned in these specifications, shall be of like effect as though shown or mentioned in both. The Contractor shall perform all activities at no extra cost to the District that are reasonably inferable from the Contract documents as being necessary to produce and/or achieve the intended results.

**5.1.5.2** The Engineer may furnish from time to time such detail drawings, plans, profiles and information as may be considered necessary for the Contractor's guidance or clarification, unless otherwise provided in the proposal, agreement or detail specifications. In cases where the Contract Work or any portion thereof is to be performed in accordance with drawings, specifications or lists of data submitted by the Contractor and approved by the Engineer, such approved drawings, submittals, etc., shall become portions of the plans and specifications regarding the specific matters to which such approval applies. The Contractor shall be solely responsible for the correctness of the measurements and other essential information submitted by it and for the correlation of the various portions and features of the Work which

are or may be affected by such measurements and information.

**5.1.5.3** Any change required by the Engineer in the drawings, submittals, etc., submitted for approval by the Contractor, shall be considered as necessary in order to comply with the requirements of the plans and specifications, and shall not be the basis of any claim for extra compensation over and above the bid price for the Work, except where changes involving extra work are expressly authorized and ordered in accordance with the section of these specifications relating to changes and extra work.

**5.1.5.4** A copy of the plans and specifications shall be kept upon the Work Site at all times during its progress and access shall at all times be accorded the Engineer.

**5.1.5.5** The Contractor shall, for the price bid, furnish all supervision, labor, materials, transportation and equipment necessary to execute the Work in every respect in a thorough, skillful, workmanlike manner in accordance with the Contract documents and to the satisfaction of the Engineer. All work shall, during its progress and until its completion, conform to the lines, elevations and grades shown on said plans and profiles.

**5.1.6 PRECEDENCE OF DOCUMENTS.** In case of any conflict, the order of precedence of the following documents in controlling the Work shall be: (1) Permits from outside agencies required by law and applicable codes or laws, (2) Change Orders, (3) Addenda, (4) Supplementary Requirements (5) Technical Specifications, (6) Plan Details, (7) Plans, (8) General Conditions, (9) Specifically referenced Standard Specifications and Drawings, e.g., Greenbook.

#### **5.1.7 INTERPRETATION/NOTIFICATION REQUIREMENTS**

**5.1.7.1 Interpretation of Plans and Specifications.** Should it appear that the Work to be performed or that the Contract documents are not sufficiently detailed or explained, or should any questions or doubts arise as to the true meaning of any part of the Contract documents, or shall an error, conflict, ambiguity or mistake be apparent or discovered in the Contract documents, including the quantity

estimates, the Contractor shall make a written request to the Engineer immediately upon discovery for correction, clarification or interpretation of the point(s) in question. Upon receipt of such request, the Engineer shall provide the Contractor a written interpretation correcting, clarifying or interpreting the point(s) in question, which interpretation shall be final and become a part of the Contract. Should any interpretation, in the opinion of the Contractor, exceed the scope of the Contract documents, written notice shall be given to the District within seven (7) calendar days of the receipt of the Engineer's interpretation and prior to proceeding with the Work in question unless directed otherwise by the District. The Engineer may amend its original interpretation, authorize extra work as a Contract Change Order and authorize an extension of time, if applicable, in accordance with the provisions of Article 5.7 (Change in the Work) or the Engineer may direct the Contractor to proceed with the original interpretation. The Contractor's failure to provide such notice or the installation of any such Work without authorization or written direction shall relieve the District of any claim for added costs or for extensions of time.

**5.1.7.2 Interpretation of Contract documents.**  
**Tenses** – The present tense includes the past and future tenses and the future the past.  
**Gender** – The masculine gender includes the feminine and neuter. The neutral gender includes the masculine and feminine.  
**Number** – The singular number includes the plural and the plural includes the singular.

**5.1.8 OWNERSHIP AND USE OF DRAWINGS, SPECIFICATIONS AND OTHER DOCUMENTS.** The Contract documents, including Contractor shop drawings and submittals, were prepared for use for the Work of this Contract only and are the sole property of the District. No part of the Contract documents shall be used by the Contractor for any other construction or for any other purpose except with the written consent of the District. Any unauthorized use of the Contract documents is at the sole risk and liability of the user.

## **ARTICLE 5.2 – DISTRICT**

**5.2.1 DISTRICT'S RIGHT TO STOP WORK.** If the Contractor fails to correct Work which is not in accordance with the requirements of the Contract documents or fails to carry out Work in

accordance with the Contract documents or for any cause whatsoever, the Engineer may order the Contractor to stop the Work, or any portion of the Work, until the cause for such order has been eliminated; however, the Engineer's right to exercise this provision shall not be for the benefit of the Contractor or any other person or entity. If the Engineer stops the Work because of conduct by the Contractor, its agents, representatives or subcontractors, no compensation in time or money shall be owed to the Contractor for such stoppage.

**5.2.2 DISTRICT'S RIGHT TO CARRY OUT THE WORK.** If the Contractor defaults or neglects to carry out Work in accordance with the Contract documents and fails within ten (10) days or within the time specified, whichever is less, after receipt of written notice from the District to commence and continue correction of such default or neglect with diligence and promptness, the District may by any means acceptable to it, without prejudice to other remedies the District may have, correct such deficiencies. In such case an appropriate Contract Change Order shall be issued deducting from payments then or thereafter due the Contractor the cost or estimated cost of correcting such deficiencies, including compensation for additional services and expenses made necessary by such default, neglect or failure. If payments then or thereafter due the Contractor are not sufficient to cover such amounts, the Contractor and/or its surety shall pay the difference to the District.

### **5.2.3 NO WAIVER OF RIGHTS**

**5.2.3.1** Observation or Inspection by the District or its authorized agents or representatives, any order or certificate for payment of money, any payment for, acceptance of the whole or any part of the Work by the District, any extension of time, any position taken by the District or its authorized agents or representatives shall not operate as a waiver of any provision of this Contract, or of any power herein reserved by the District or any right to damages. No waiver of any breach of Contract shall be held to be a waiver of any other or subsequent breach, and payment shall not be deemed to be the equivalent of acceptance.

**5.2.3.2** All remedies provided in this Contract shall be taken and construed as cumulative; that is, in addition to each and every remedy

provided herein, the District shall have any and all equitable and legal remedies that it would otherwise have.

#### **5.2.4 DISTRICT'S ADMINISTRATION OF THE CONTRACT**

**5.2.4.1** The District will administer the Contract as described in the Contract documents, unless notice is given to the Contractor that a Construction Manager or like entity has been retained to administer the Contract.

**5.2.4.2** The Work will be performed under the jurisdiction of the Engineer, who may execute general control over the conduct of the Work as may be necessary to safeguard the interest of the District. The Contractor shall promptly comply with any and all orders and instructions given by the Engineer in accordance with the terms of this Contract. The Contractor assumes all risks and consequences of performing the Contract in accordance with any order, including but not limited to, instruction, direction, interpretation or determination, of anyone not authorized to issue such order.

#### **5.2.5 AUTHORITY OF ENGINEER**

**5.2.5.1** The Engineer will decide all questions which may arise as to acceptability of:

**5.2.5.1.1** Materials furnished.

**5.2.5.1.2** Quality of workmanship.

**5.2.5.1.3** Manner of work performed.

**5.2.5.1.4** Rate of work progress.

**5.2.5.1.5** Equipment used in work performance.

**5.2.5.1.6** Labor furnished, including acceptability of subcontractors.

**5.2.5.1.7** Arrangements for public access.

**5.2.5.1.8** Traffic control devices furnished.

**5.2.5.1.9** Pay estimates.

**5.2.5.1.10** Work hours.

**5.2.5.2** The Engineer will decide questions arising under the Contract, including but not limited to:

**5.2.5.2.1** Interpretation of Contract documents, including plans and specifications.

**5.2.5.2.2** Interpretation of applicable codes.

**5.2.5.2.3** Quantity of work performed.

**5.2.5.2.4** Acceptable fulfillment of the Contract on the part of the Contractor.

**5.2.5.3** Except as otherwise provided herein or by law, the decision of the Engineer will be final. The Engineer has authority to enforce and make effective such decisions that the Contractor fails to promptly carry out.

#### **5.2.6 DISTRICT'S OBSERVATION OF WORK**

**5.2.6.1** Inspectors employed by or on behalf of the District shall be authorized to observe all work done and all materials furnished. Such observation may extend to all or any part of the Work and to the preparation, fabrication or manufacture of the materials to be used. The inspector is not authorized to revoke, alter or waive any requirements of the specifications or Contract documents. The inspector is authorized to call to the attention of the Contractor any failure of the Work or materials to conform to the specifications and Contract. He shall have the authority to reject materials or suspend the Work until any questions at issue can be referred to and decided by the Engineer.

**5.2.6.2** The inspector shall in no case act as foreman or perform other duties for the Contractor, nor interfere with the management of the Work by the latter. Any advice that the inspector may give the Contractor shall not be construed as binding to the Engineer in any way or as releasing the Contractor from fulfilling all the terms of the Contract.

**5.2.6.3** If the Contractor refuses to suspend operations on verbal order, the inspector shall issue a written Notice to Stop Work giving the reason for shutting down the Work. (See Form 8, "Notice to Stop Work," Appendix A) After placing the order in the hands of the Contractor or its agent, the inspector shall immediately leave the job. Work done during the absence of the inspector will not be accepted nor paid for, and any associated expense shall be the sole responsibility of the Contractor.

**5.2.6.4** Observation of a method of procedure, process or system of operations of the Contractor, or failure of the Engineer to warn the Contractor that the method or methods of construction adopted by it are hazardous to persons or to property, shall not relieve the Contractor of its obligations hereunder, including the obligations of indemnification of the District, nor give rise to any claims against the District.

**5.2.6.5** If the project is wholly or partially federally funded, the Work Site may be inspected at any time by a representative of the funding federal agency.

**5.2.7 DEFECTIVE WORK – NOTICE TO CONTRACTOR**

**5.2.7.1** If, in the opinion of the Engineer, Work is not being done in accordance with any applicable codes or laws or the plans and specifications, written notice as provided in Subsection 5.2.2 shall be given to the Contractor or its authorized agent. (See Form 6, "Nonconformance Report," Appendix A) Written notice to any foreman or agent in charge of any portion of the Work in the absence of the Contractor shall be considered as notice to the Contractor.

**5.2.7.2** Work which is defective in its construction or deficient in any of the requirements of these specifications, will not be considered as accepted in consequence of the failure of any employee of the District or inspector connected with the Work to point out said defects or deficiency during construction. The Contractor shall at its sole expense correct any imperfect work whenever discovered. If Contractor refuses or neglects to replace defective work, such work may be replaced by the District in accordance with 5.2.2, after notice to the Contractor and its sureties, at the expense of the Contractor, and the Contractor and its sureties shall be liable therefor. If directed by the District, the Contractor shall at its sole cost uncover and/or expose work for its inspection by the District.

**5.2.8 ACCEPTANCE OF NONCONFORMING WORK.** If in the judgment of the District, it is undesirable or impracticable to replace any defective or nonconforming Work, the compensation to be paid to the Contractor shall be reduced by Contract Change Order by such amount as in the judgment of the District shall

deem equitable.

**5.2.9 RECEIPT OF THIRD PARTY CLAIMS.**

Upon receipt of any third party claim related to this contract, the District shall notify the contractor of the receipt of any third party claim relating to the contract. The District shall be entitled to recover its reasonable costs providing such notification.

**ARTICLE 5.3 – CONTRACTOR**

**5.3.1 REVIEW OF CONTRACT AND FIELD CONDITIONS**

**5.3.1.1** The Contract documents are not complete in every detail but show the purpose and intent only and the Contractor shall comply with the Contract documents true intent and meaning, taken as a whole, and shall not avail itself of any manifest error, omission, discrepancy or ambiguity which appears in the Contract documents, instructions or Work performed by others.

**5.3.1.2** The Contract documents are complementary and what is called for by any one shall be binding as if called for by all. This provision does not negate the precedence of documents outlined in Subsection 5.1.6.

**5.3.1.3** Before ordering any materials or doing any work, the Contractor shall verify all measurements, dimensions, elevations and quantities. No extra charge or compensation over and above payment for the actual quantities of the various items of work at the respective bid prices will be allowed on account of differences between actual measurements, dimensions, elevations and quantities and those indicated on the drawings and in the specifications; any difference therein shall be submitted to the Engineer in accordance with Subparagraph 5.1.7.1 for consideration before proceeding with the Work. The quantities noted in the schedules of the proposal are estimates for comparing bids only.

**5.3.1.4** The Contractor shall notify the District in writing immediately or no later than five (5) calendar days upon the discovery of errors, omissions, discrepancies or ambiguities in the Contract documents as provided in Article 5.1, at Subsection 5.1.7.

**5.3.1.5** If the Contractor proceeds with the work

without receiving an interpretation as provided in Article 5.1, at Subsection 5.1.7, the District shall be relieved of any liability and Contractor shall be responsible for all resulting damage and defects.

**5.3.1.6** As required to maintain the progress of the Work, the Contractor shall review the appropriate portions of the Contract documents a minimum of thirty (30) days prior to the commencement of the related Work for the express purposes of checking for any manifest errors, omissions, discrepancies or ambiguities and shall notify the District of any as required by Subparagraph 5.3.1.4, above. The Contractor shall not be entitled to any compensation for delays, disruptions, inefficiencies or additional administrative effort caused by the Contractor's untimely review of the Contract documents.

**5.3.1.7** The Contractor shall be responsible for its costs to implement and administer a Request for Information (RFI) system throughout the Contract Time. Regardless of the number of RFIs (or written directions) issued, the Contractor will not be entitled to additional compensation or additional Contract time unless the cause and impacts of each RFI are identified and attributable to parties other than the Contractor. The Contractor shall be responsible for the District's administrative costs for answering RFIs where the answer could reasonably be found by reviewing the Contract documents; such costs may be deducted from progress payments. If the RFIs alter the design of the Work without altering its intent, the Contractor shall be responsible for the District's administrative costs including engineering costs for such alteration, revision or substitution.

## **5.3.2 SUPERVISION AND CONSTRUCTION PROCEDURES**

**5.3.2.1** The Contractor shall supervise and direct the Work, using its best skill and attention, and shall determine, subject to applicable law, the means and methods to be implemented. The Contractor is at all times responsible for the Work Site until acceptance of the project as defined in Article 5.9. The Contractor shall at all times during the performance of the Contract prosecute the Work with such forces and equipment as, in the opinion of the Engineer, are appropriate to complete the different portions of the Work in the order required and within the specified time, and to secure a satisfactory

quality of Work. Whenever requested by the Engineer, Contractor shall submit a Daily Activity Report to the Engineer for each Work day including weekends and holidays, which shall include the information addressed as required in the pre-construction conference and on the form provided by the District. Failure to submit daily the required report shall be a material default and justify withholding Progress Payments and, following reasonable notice of not less than seventy-two (72) hours, termination for default. The delivery of Daily Activity Report to the District shall not be deemed the acceptance of the accuracy of the information contained therein. The District shall have no obligation to correct any discovered discrepancies or errors therein, but may, at its discretion, notify the Contractor of any such error or discrepancy.

### **5.3.2.2 Supervision:**

**5.3.2.2.1 General:** The Contractor shall at all times, while the Work is in progress, be represented on the Work in person, or by superintendents, foremen, managers, or other duly designated and authorized representatives or agents. The work of such representatives shall be limited to supervisory duties only. The Contractor shall not designate a subcontractor as its representative. In the event the Contractor's representative's authority is limited in any way, the Contractor shall notify the District within ten (10) days after entering into the Contract of such limitation.

**5.3.2.2.2 Contractor's Residence:** The Contractor or its authorized representative shall reside in San Diego County from the start of the Work to final acceptance of the Work and its residence in San Diego County shall have an active telephone.

**5.3.2.2.3 Contractor's Headquarters:** Before starting Work, the Contractor shall give the Engineer a written statement of the address and telephone number of the Contractor's headquarters in San Diego County for the duration of the Work.

**5.3.2.2.4 Contractor's Representative:** When a Contractor cannot be in person on the Work site during its progress, it shall designate in writing to the Engineer the name of its authorized representative in charge of the Work. When a Contractor consists of a multiple entity such as, but not limited to, two or more persons,

partnerships, corporations, firms or other entities, such Contractor shall designate in writing to the Engineer the name of the authorized representative in charge of the Work.

**5.3.2.2.5 Contractor's Representative – Responsibility of:** In the absence of the Contractor, its authorized representative shall be empowered in writing to act for the Contractor. Any order given by the Engineer to the Contractor's authorized representative shall be construed to have been given to the Contractor.

**5.3.2.2.6 Contractor – Availability of:** The Contractor or its authorized representative shall be available day and night for all the calendar days during the Contract Time. The Contractor or its authorized representative shall provide the District with a prioritized list of personnel to be contacted during emergency situations who can respond to emergencies and/or have the authority to direct other employees to respond to such emergencies. This list shall contain the names and local telephone numbers of these individuals and shall be submitted on or before commencement of construction of the Work. The listed personnel shall be subject to call by the Engineer at any time (24 hours a day) during the Contract Time, when, in the opinion of the Engineer, its presence is required on the Work Site or for any other purpose related to the Work.

**5.3.2.3** The Contractor shall conduct the Work in compliance with all laws and regulations of the United States Government, the State of California, the County of San Diego, the District and the appropriate municipal jurisdiction, limiting or controlling the Work in any manner. Unless otherwise provided by the Contract, the Contractor shall at its own expense obtain all necessary permits, including but not limited to building permits, licenses and pay all fees and taxes required by law. The District will provide at its own cost all required permits and licenses to construct works within the respective rights-of-way and properties owned by the United States Government, the State of California, the County of San Diego, cities comprising the District, the District, and railroads or other public utilities.

### **5.3.3 LABOR AND PREVAILING WAGES**

**5.3.3.1 Labor:** None but skilled personnel shall be employed on Work requiring special

qualifications, and when required by the Engineer, the Contractor shall take the necessary action to remove from the Work any person who is, in the opinion of the Engineer, disorderly, dangerous, insubordinate, incompetent or otherwise objectionable. Such removal shall not be the basis of any claim for compensation or damages against the District or any of its officers.

**5.3.3.1.1 Eight Hour Day:** Unless as otherwise excepted by law, neither Contractor nor any subcontractor doing work pursuant to the terms of this Contract shall require or permit any worker to work more than eight (8) hours per day and forty (40) hours in any one week, provided, however, work performed in excess of eight (8) hours per day shall be compensated at the rate of no less than one and one-half times the basic rate of pay.

**5.3.3.1.1.1** Contractor shall, as a penalty to District, forfeit twenty-five Dollars (\$25.00) for each worker employed in the execution of this Contract by Contractor or by any subcontractor for each calendar day during which such worker is required or permitted to work more than eight (8) hours in one calendar day and forty (40) hours in any one calendar week unless compensation for all hours worked in excess of eight (8) hours per day and forty (40) hours per week is not less than as required by law.

**5.3.3.1.1.2** Contractor and each subcontractor shall keep an accurate record showing the name, labor classification and actual hours worked each calendar day and each calendar week by each worker employed by it in connection with the Work performed pursuant to this Contract, and shall make such records available for inspection at all reasonable hours by the District and the Division of Labor Standards Enforcement. Neglecting to comply with this section is a misdemeanor.

**5.3.3.1.2** A Contractor or subcontractor who has been debarred pursuant to Labor Code section 1777, et seq. shall not bid, work on or be awarded any District Contracts.

### **5.3.3.2 Wage Rates (Prevailing Wages):**

**5.3.3.2.1** In accordance with the provisions of Labor Code section 1773, the District has ascertained from the Department of Industrial Relations the general prevailing rate of per diem



wages (which rates include employer payments for health and welfare, vacation, pension and similar purposes) and the general prevailing rate for holiday and overtime work in the locality in which the Work is to be performed under this Contract for each craft, classification or type of worker needed to perform the Contract, which rates are on file and available for inspection at District offices at 1400 Tidelands Avenue, National City, California. A copy of the wage rates shall be posted on the Work Site by the Contractor.

**5.3.3.2.2** Contractor and each subcontractor shall pay not less than the specified prevailing rates of wages to all workers employed in the execution of this Contract. As allowed by law, the Contractor shall, as penalty to District, forfeit not more than Two Hundred Dollars (\$200.00) for each calendar day, or portion thereof, for each worker paid less than the stipulated prevailing rates for such Work or craft in which such worker is employed for any Work done under this Contract, including Work for any subcontractor. The amount of said forfeiture shall be determined by the Labor Commissioner in accordance with Labor Code section 1775. The difference between such stipulated prevailing wage rates and the amount paid to each worker for each calendar day or portion thereof for which each worker was paid less than the stipulated prevailing wage rate shall be paid to each worker by the Contractor pursuant to the provisions of Labor Code section 1775. The District shall not be liable or responsible in any manner to any subcontractor or worker who is paid less than the prevailing rate.

**5.3.3.2.3** The District shall not recognize or be responsible for any claim for additional compensation because of payment by the Contractor for any wage rate in excess of the wage rate set forth in the Contract. The possibility of wage increases is one of the elements to be considered by the Contractor in determining its bid.

**5.3.3.2.4** Any Contractor who is awarded a public works Contract and who intends to use a craft or classification not shown on the general prevailing wage determinations shall pay the wage rate of that craft or classification most closely related to it as shown in the general wage determinations effective on the bid date of the project.

**5.3.3.2.5** The Contractor shall comply with Labor Code section 1775, (b).

**5.3.3.3** Payroll records:

**5.3.3.3.1** Contractor and each subcontractor shall keep an accurate, certified payroll record of the name, address, social security number, work classification, occupation, straight time and overtime hours worked each day and week, and actual per diem wages paid to each journeyman, apprentice, worker or other employee employed by it in connection with Work performed under this Contract. The Contractor shall submit, on a weekly basis, a certified copy of each payroll via LCPtracker to the District. In accordance with Section of the Submittal Procedures, the Contractor shall submit, on a weekly basis, a certified copy of each payroll electronically via the software LCPtracker. Electronic submission is a web-based system, accessed on the World Wide Web by a web browser. Each contractor will be given a Log-On identification and password to access the San Diego Unified Port District's reporting system. Use of the system will entail data entry of weekly payroll information including; employee identification, labor classification, total hours worked and hours worked on this project, wage and benefit rates paid etc. The Contractor's payroll and accounting software might be capable of generating a 'comma delimited file' that will interface with the software. Contractor must require all lower-tier subcontractors the mandatory requirement to use LCPtracker to provide required labor compliance documentation. Lower-tier subcontractors will be given a Log-On identification and password from the Contractor. Training options will be provided to the Contractor. The use of LCPtracker by the Contractor is mandatory. Access to LCPtracker will be provided at no cost to the contractor. In order to utilize LCPtracker, the contractor needs a computer and internet access. A digital camera and a scanner may be useful. For more information, go to [www.lcptracker.com](http://www.lcptracker.com). To Login, go to [www.lcptracker.net](http://www.lcptracker.net) and from the homepage, select LOGIN and enter the Username and Password that will be provided to you by the District. Certified copies of all such records and the U.S. Department of Justice Form I-9 (or its equivalent) shall be made available for inspection or furnished upon request to the District, the Division of Apprenticeship Standards and the Division of Labor Standards

Enforcement in accordance with the provisions of Labor Code section 1776. Certified copies of such record shall be made available to the public as provided in Section 1776. A certified copy of an employee's payroll record shall be made available for inspection or furnished to the employee or its representative on request. Contractor shall be responsible for compliance with these provisions and with the requirements of Labor Code section 1776.

#### **5.3.4 SUBMITTALS**

**5.3.4.1** The term "submittals" includes shop drawings, drawings, diagrams, layouts, schematics, description literature, illustrations, schedules, samples, product, performance and test data, and similar materials furnished by the Contractor to explain in detail specific portions of the Work required by the Contract.

**5.3.4.2** If this Contract requires submittals or if requested by the Engineer, the Contractor shall submit such submittals as required to maintain the progress of the Work or as specified by the Contract documents. The Contractor shall coordinate all such submittals, and review them for accuracy, completeness and compliance with the Contract requirements and shall indicate its approval thereon as evidence of such coordination and review. Submittals provided to the Engineer without evidence of the Contractor's approval will be returned for re-submission. The Engineer will indicate its approval or disapproval of the submittals as specified in Subparagraph 5.3.4.4 below and if not approved as submitted shall indicate its reasons. No work shall be performed without an approved submittal for such specific work, and any Work done prior to such approval shall be at the Contractor's risk. Approval by the Engineer shall not relieve the Contractor from responsibility for any errors or omissions in such drawings, nor from responsibility for complying with the requirements of this Contract, nor shall said review relieve the Contractor of any obligation thereunder, including without limitation the removal and replacement of defective Work, materials and equipment which may be rejected by the Engineer notwithstanding such review, except with respect to variations described and approved in accordance with Subparagraph 5.3.4.3 below. Submittals are part of the Contract Work.

**5.3.4.3 Submittal Variations:** If the submittals

show any variations from the Contract requirements, the Contractor shall describe such variations in writing, separate from the drawings, at the time of submission. If the Engineer approves any submittals with unidentified variation(s), the Contractor's failure to specifically identify each variation as set forth above, shall waive any implied or express approval obtained by the District.

**5.3.4.4** The Contractor shall submit to the Engineer for approval six (6) sets (unless otherwise indicated) of all submittals as called for under the various headings of these specifications. Four (4) sets (unless otherwise indicated) of all submittals will be retained by the Engineer and two sets will be returned to the Contractor. Submittals will be reviewed by the Engineer and returned to the Contractor within 21 working days and will be: (1) returned marked "Approved," (2) returned marked "Approved With Corrections Noted," or (3) returned marked "Disapproved, Revise and Resubmit as Noted."

**5.3.4.5** Submittals marked "Disapproved, Revise and Resubmit as Noted" and returned to the Contractor shall be corrected by the Contractor to indicate compliance with design requirements and resubmitted for review before proceeding with fabrication. Drawings marked "Approved with Corrections Noted" shall be corrected, and may be issued by the Contractor for fabrication without further review and the Work shall be performed pursuant to the noted corrections.

**5.3.4.6** Full compensation for furnishing and revising all submittals shall be considered as included in the prices paid for the Contract items of Work to which such submittals relate and no additional compensation will be allowed.

**5.3.4.7 Trade Names and Alternatives:** Certain materials, products, things or services to be incorporated in the Work may be designated in the specifications by specific brand or trade name of comparable quality or utility followed by the words "or equal" so that the Contractor may furnish any equal material, product, thing or service. The District shall, if aware of an equal product manufactured in California, name such product in the specifications. Only one such "or equal" item will be permitted per submitted item. The Contractor may submit a request for a substitution of "an equal" item; provided,

however, said data need not be submitted less than thirty-five (35) days after the award of the Contract. Any such submission after said thirty-five (35) day period shall be provided in ample time so as not to delay progress of the Work. If the District rejects the substitution of an "or equal" item, the Contractor shall provide the specified material, product, thing or service without extra cost to the District.

### **5.3.5 MATERIALS AND SAMPLES**

**5.3.5.1** All materials shall be new and of the specified quality and fully equal to samples, where samples are required or requested. The Contractor shall furnish to the Engineer for review or test, whenever requested and free of charge, samples of all materials proposed to be used in the Work. It shall also submit any required detailed drawings of articles or equipment for District approval. Rejected materials must be immediately removed from the Work Site and shall not be brought again upon the Work or used in the Work.

#### **5.3.5.2 Materials furnished by the District:**

**5.3.5.2.1** In cases where the District furnishes all or a portion of the equipment or materials to be used in the Work ("materials"), the Contractor shall accept delivery of such materials as may be provided. If the Contractor is required to haul such materials under this Contract to the Work Site, it shall pick them up promptly after notification by the Engineer, and shall pay at its own cost any demurrage or other charges which have accrued due to its failure to pick up the materials promptly.

**5.3.5.2.2** Contractor shall be responsible for the materials including proper storage and handling from the time it receives them until final acceptance of the Work and it shall replace or repair, at its own cost in a manner satisfactory to Engineer, any of the materials which are lost or damaged after the Contractor's receipt of same.

**5.3.5.2.3** Any District furnished materials which remain unused at the completion of the Work shall be delivered by the Contractor to the District's storage yard designated by the Engineer.

**5.3.5.2.4** All compensation to be received by the Contractor for handling and protecting District furnished material is included in the Contract

price, and no extra compensation will be paid to the Contractor for complying with the provisions of this section.

**5.3.6 GUARANTEE.** In addition to, but not in limitation of, the provisions of California Code of Civil Procedure sections 337.1 and 337.15, all work shall be guaranteed by the Contractor for a period of one (1) year unless otherwise specified from the date of acceptance of the Work or part thereof (see Section 5.9.4) against defective workmanship and materials furnished by the Contractor. The Contractor shall promptly replace or repair, in a manner satisfactory to the Engineer, any such defective work after notice to do so from the Engineer, and upon the Contractor's failure to make such replacement or repairs promptly, the District may perform this Work and the Contractor and its sureties shall be liable for the cost thereof. For any Work which is replaced or repaired pursuant to this provision, a new one (1) year guarantee period shall begin after acceptance by the District of the repaired or replaced Work.

### **5.3.7 SCHEDULES**

**5.3.7.1 Schedule of Values:** Within ten (10) days after the award of the Contract, Contractor shall furnish a schedule of values (cost itemization), which after being approved by the Engineer, will become the basis for computing periodic payments. Failure to timely provide a schedule of values shall be grounds for withholding payment to the Contractor.

**5.3.7.2** Before the preparation of the Contractor's Progress Schedule, Contractor shall inspect the project Work Site in order to familiarize itself with the condition of the existing area where it will perform the Work.

**5.3.7.3** Contractor shall submit a practicable Progress Schedule, in quadruplicate, to the Engineer at the pre-construction conference and be prepared to discuss the Progress schedule, events and construction procedures at the time. No Work shall be allowed to proceed unless and until a Progress Schedule is submitted. In the event a Notice to Proceed has issued, no time extension or compensation will be allowed to Contractor for failure to comply with this provision.

**5.3.7.4** The Contractor may furnish the Progress Schedule on a form of its choice or, if

requested, the Engineer will furnish a form for the Contractor's use. However, the form shall clearly show the order in which the Contractor proposes to carry out the Work, the dates on which it will start the salient features of the Work (including procurement of materials, plant and equipment), production rates and the proposed dates for completing said salient features. The Progress Schedule submitted shall be consistent in all respects with the time constraints and sequencing requirements of the Contract.

**5.3.7.5** An updated Progress Schedule shall be submitted monthly, or as requested by the Engineer, to show the progress of the Work. In any event, if the Contractor fails to submit said updated Progress Schedule within ten (10) calendar days after a written request by the Engineer, the Engineer shall have the right to withhold progress payments for any work until a satisfactory Progress Schedule is submitted to the Engineer.

**5.3.7.6** The capacity of the construction plant, sequence of operations and methods of operations shall be such as to ensure the completion of the Work within the time specified in the Progress Schedule.

**5.3.7.7** When the Contractor is to furnish major items of equipment or materials, the Progress Schedule shall include the proposed dates of manufacture and shipment of these items and the names and locations of factories or other sources from which said items are to be obtained.

**5.3.7.8** Total Float is the number of days by which a part of the Work in the schedule may be delayed from its early dates without necessarily extending the Contract Time. Contract Float is the number of days between the Contractor's anticipated date for early completion of the Work, or specified part, and the corresponding Contract Time. Total Float and Contract Float belong to the project and are not for the exclusive benefit of any party. They shall be available to the District, its agents, or the Contractor to accommodate changes in the Work or to mitigate the effect of events which may delay performance or completion. Each party will monitor and optimize the use of float for the benefit of the project.

**5.3.7.9** An early completion schedule is one which anticipates completion of all or specified

part of the Work ahead of the corresponding Contract Completion Date. Because Contract Float belongs to the Project, the Contractor shall not be entitled to any extension in Contract Time, or recovery for any delay incurred because of extensions in an early completion date, until all Contract Float is used or consumed and performance or completion of the Work extends beyond the Contract Completion Date. The Contractor shall adjust or remove any float suppression techniques, e.g., preferential sequencing (crew movements, equipment use, form reuse, etc.) extended durations, imposed dates, scheduling of Work not required for a Contract Time as required Work, and others, as prerequisite to a request for an increase in Contract price or Contract Time.

### **5.3.8** RECORD DRAWINGS AND TESTS

**5.3.8.1** The Contractor shall maintain at the Work Site a record set of full-size project drawings upon which all field changes are recorded on a daily basis. The Contractor shall provide and maintain in good order, in the field office at the initial cap work site, one complete set of blue-line prints recording the exact location, by dimensions, and the exact depth, by elevation, of all underground or otherwise concealed utilities. It shall record, by dimension and/or scale drawings, all such concealed work as actually installed. All information necessary to maintain and/or service any concealed work shall be noted on these record drawings. This data shall be legibly recorded on blue-line prints (furnished by the Engineer) to the satisfaction of the Engineer. Records shall be kept up to date with all entries checked by the Engineer before the work is buried or otherwise concealed. In the event the Contractor fails to maintain record drawings up to date (see Form 3, "As Built Drawing Certification," Appendix A), Engineer may withhold progress payments, or any part thereof, until satisfactory, up to date record drawings are produced by the Contractor.

**5.3.8.2** Upon completion of the Work and as a condition precedent to acceptance and the issuance of final payment, the Contractor shall deliver to the Engineer a complete set of corrected prints, in good condition and with complete installation and every change in the Work indicated thereon whether concealed or visible.

**5.3.8.3** Any work showing faults under test, and

any Work not in accordance with the specifications and the accompanying drawings, shall be made good by the Contractor at its own expense.

**5.3.8.4** Should the Contractor refuse or neglect to make any tests necessary to satisfy the Engineer or its representative that it has carried out the true intent and meaning of the specifications, the District may make such tests and charge the expense to the Contractor, to be retained out of a progress or final payment as provided in these General Conditions.

**5.3.8.5** The District may require the testing of materials by a competent testing laboratory of its selection or by other means. The cost of the material to be tested, delivered to the point of testing, shall be borne by the Contractor and the cost of the initial tests will be borne by the District. The Contractor shall pay all costs for subsequent tests where work or material fails to pass initial tests. Any Work or material showing faults under test shall be corrected by the Contractor at its own expense.

**5.3.9** UTILITIES. Contractor shall provide at its own cost all utilities, including water, which are necessary for performance of Work. Said utilities, including water, shall be from sources approved by the Engineer.

**5.3.10** RIGHT-OF-WAY. The right-of-way for Work to be constructed under this Contract will be provided by the District. Right-of-way Agreements may be inspected at the office of the Engineer.

**5.3.11** SANITATION. The Engineer may establish sanitary and police rules and regulations for all forces employed under this Contract and the Contractor shall be responsible for compliance therewith, and in the event of noncompliance, the Engineer may enforce them at the expense of the Contractor. The Contractor shall provide its own sanitary facilities unless permission to use District facilities is granted by the District in the Supplementary Requirements.

**5.3.12** PRESERVATION OF MONUMENTS. The Contractor shall not disturb any monuments or stakes without permission of the Engineer, and Contractor shall bear the expense of resetting any monuments or stakes which may be disturbed without permission.

**5.3.13** DATUM PLANE AND MEASUREMENTS. All distances shown on the plans, profiles or other drawings are in feet and decimals of the foot or in feet and inches. Depth or elevations are in feet and decimals of a foot, and are above (plus) or below (minus) the U.S. Coast and Geodetic Survey zero or mean lower low water as established for the Bay of San Diego, unless another datum plane is indicated on the drawings.

**5.3.14** SETTING STAKES. The Contractor shall lay out its work from District established base lines and bench marks indicated on the drawings and shall be responsible for all measurements in connection with the layout. The Contractor shall furnish, at its own expense, all stakes, templates, platforms, equipment, tools, materials, and labor required to lay out any part of the Work. The Contractor shall be responsible for executing the Work to the lines and grades that may be established or indicated by the District. The Contractor shall be responsible for maintaining and preserving all stakes and other marks established by the District until authorized to remove them. If such marks are destroyed by the Contractor or its agents before their removal is authorized, the District may replace them and deduct the expense of the replacement from any amount due or to become due to the Contractor.

**5.3.15** TRENCHES OR OTHER EXCAVATIONS AND HAZARDOUS OR CONTAMINATED CONDITIONS

**5.3.15.1** In Contracts exceeding \$25,000.00, the Contractor shall comply with Labor Code section 6705. In the event an excavation is five (5) or more feet in depth, the Contractor shall cause a competent person to be placed at the site of the Work for the purposes of observing backfilling operations in those cases where the backfill operator is unable to see into the excavation. The Contractor shall make sufficient excavation to construct all of the Work shown on the drawings or specified herein and shall abide by the Construction Safety Orders issued by the Division of Industrial Safety of the State of California. The Contractor shall submit to the Engineer a detailed plan showing the design of shoring, bracing, sloping or other provisions to be made for worker protection. If such plan varies from the shoring system standards established by the Division of Industrial Safety, the plan shall be prepared by a registered civil

engineer or structural engineer. No shoring, sloping or protective system less effective than that required by the Division of Industrial Safety shall be used. All permits for excavating in excess of five (5) feet shall be obtained by the Contractor and shall be the Contractor's sole responsibility.

**5.3.15.2** If this Contract involves digging trenches or other excavations below the surface no matter the depth, the Contractor shall promptly, and before the following conditions are disturbed, notify the District, in writing of any:

**5.3.15.2.1** Material that the Contractor believes may be material that is hazardous waste, as defined in Section 25117 of the Health and Safety Code, that is required to be removed to a Class I, Class II or Class III disposal site in accordance with provisions of existing law.

**5.3.15.2.2** Subsurface or latent physical conditions at the site differing from those indicated.

**5.3.15.2.3** Unknown physical conditions at the site of any unusual nature, different materially from those ordinarily encountered and generally recognized as inherent in Work of the character provided for in the Contract.

**5.3.15.3** The District shall promptly investigate the conditions, and if it finds that the conditions materially differ, or involve hazardous waste and cause a decrease or increase in the Contractor's cost of, or the time required for, performance of any part of the Work, may issue a Contract Change Order under the procedures described in this Contract.

**5.3.15.4** In the event that a dispute arises between the District and the Contractor whether the conditions materially differ, involve hazardous waste, or cause a decrease or increase in the Contractor's cost of or time required for performance of any part of the Work, the Contractor shall not be excused from any scheduled completion date provided for by the Contract, but shall proceed with all Work to be performed under the Contract. The Contractor shall retain any and all rights provided either by Contract or by law which pertain to the resolution of disputes and protests.

**5.3.15.5** In the event conditions involve

hazardous waste or contaminated material or other materials which may require remediation or special handling, the Contractor shall not move or disturb the materials or objects and shall immediately notify the Engineer both verbally and in writing. The District may take all action necessary to remediate or handle such materials, including, but not limited to, hiring a third party Contractor to perform the remediation or other work or issue a Contract Change Order to the Contractor.

### **5.3.16 EXISTING UTILITIES, IMPROVEMENTS AND OBSTRUCTIONS**

**5.3.16.1** Whenever any pole, structure, culvert, conduit, cable or other obstruction, either above or below ground surface within the area to be utilized by the Contractor in the performance of the Work is, or may be affected by the Contractor's operations, the Contractor shall preserve the same intact or it shall make such arrangements with the owner of same for its protection, support, alteration or removal and reinstallation, as may be required by the conditions encountered.

**5.3.16.2** The Contractor shall notify in advance and cooperate with each owner of poles, structures, pipes, culverts, conduits, cables or other improvements that may be encountered or affected in any way by the Work under this Contract. It shall be the responsibility of the Contractor to verify the existence and exact location of existing utilities prior to construction.

**5.3.16.3** Where water mains or services are altered or removed and reinstalled either to avoid interference with the Work under this Contract or for the convenience of the Contractor, such alteration, removal and reinstallation shall be performed in accordance with the rules and regulations of the owner, and the cost shall be borne as outlined in the following paragraphs.

**5.3.16.4** It shall be the Contractor's responsibility at its sole expense to verify the existence and the exact location of existing underground utilities prior to excavation. Contractor shall pothole to determine depths and exact location of utilities prior to excavation in the area. The Contractor shall uncover sewer laterals, telephone and electric conduits, water mains and gas mains or any other major utility crossing and other high-risk underground facilities in

advance of trenching operations sufficient to permit grade changes, should such changes be required. The cost of such work shall be included in the Bid for items of work necessitating such location.

**5.3.16.5** Unless otherwise specifically provided in these Contract documents, all costs of protecting, potholing, supporting, altering, obliterating, removing, salvaging, reconstructing and reinstalling pipes, poles, structures, trees and other obstructions, shall be borne by the Contractor, including facilities which are altered or removed and reinstalled for the Contractor's convenience, except:

**5.3.16.5.1** Unless otherwise provided, where a subsurface obstruction is encountered which is not shown on the Contract drawings or mentioned in the specifications.

**5.3.16.5.2** Where it is necessary to remove or alter obstructions which are maintained under a District franchise, ordinance, Contract, permit or other agreement by the terms of which the obstruction is required to be moved or adjusted.

**5.3.16.5.3** The District shall not be required to indicate the presence of existing service laterals or appurtenances whenever the presence of such utilities on the Work Site can be inferred from the presence of other visible facilities, such as buildings, meter and junction boxes, on or adjacent to the site of the construction; provided, however, nothing herein shall relieve the District from identifying main or trunklines in the plans and specifications. The District shall compensate the Contractor for the costs of locating, repairing damage not due to the failure of the contractor to exercise reasonable care, and removing or relocating such utility facilities not indicated in the plans and specifications with reasonable accuracy, and for equipment on the project necessarily idled during such work.

**5.3.16.6** Except as otherwise expressly provided herein, the Contractor shall not be entitled to any additional compensation due to the presence of, or interference, delays or expense caused by obstructions, or the removal and/or replacement of obstructions where such obstructions could have been reasonably anticipated and such removal and/or replacement is required for proper completion of the Work. The Contractor shall not be assessed liquidated damages as

provided by Subsection 5.8.3 for delay in the completion of the Work, when such delay was caused by the failure of the District or the owner of the utility facilities as provided by Government Code section 4215.

**5.3.16.7** Where the Work requires the removal of or damage to existing pavement, sidewalks, curbs, lawns, shrubbery, trees, hedges, gardens, drives, walls, fences, buildings or other improvements, the Contractor shall take precautions to limit the removal or damage to the least practicable amount; and it shall at its own cost replace or restore said improvements to as near its original location and condition as it reasonably possible, except as otherwise provided. Great care shall be exercised in placing and compacting backfill in areas where improvements are to be placed upon said backfill.

**5.3.16.8** Trees shall not be removed without the express permission of the Engineer or as shown in the Contract documents. Damage to or excessive trimming of trees in the street or right-of-way shall be avoided. If directed by the District, the Contractor shall replace with like kind any tree removed and/or overly trimmed in violation of this provision.

**5.3.17 ROYALTIES AND PATENTS.** The Contractor shall hold and save the District, its officers, agents, servants and employees harmless from liability of any nature or kind, or any damages, claims for damages, costs or expenses in law or equity, including attorneys' fees therefor, for or on account of any infringement of the patent rights, copyright or trademark of any person of any patented invention, article or appliance included in the material or supplies furnished under this Contract, and should the Contractor, its agents, servants, employees, or any of them, be enjoined from furnishing or using any invention, article, material or appliance supplied or required to be supplied or used under this Contract, the Contractor shall promptly substitute other articles, materials or appliances in lieu thereof, of equal efficiency, quality, finish, suitability and market value and satisfactory in all respects to the Engineer. In the event that the Engineer elects, in lieu of such substitutions, to have supplied and to retain and use any such invention, article, material or appliance as may by this Contract be required to be supplied, then the Contractor shall pay such royalties and

secure such valid licenses as may be requisite and necessary to enable the District, its officer, agents, servants and employees, or any of them, to use such invention, article, material or appliance without being disturbed or in any way interfered with by any proceeding in law or equity on account thereof. Should the Contractor neglect or refuse promptly to make the substitution hereinbefore required, or to pay such royalties and secure such licenses as may be necessary and requisite for the purpose aforesaid, then in that event, the Engineer shall have the right to make such substitution, or the District, its agents, officers, servants and employees, may pay such royalties and secure such licenses and charge the cost thereof against any money due the Contractor from the District or recover the amount thereof from its sureties, notwithstanding final payment under this Contract may have been made. The provisions of this paragraph do not apply to articles which the Contractor is required to manufacture or furnish in accordance with detail drawings furnished by the District, its officers, agents, servants, employees or any of them included in this Contract. The provisions of this paragraph shall apply, however, where such drawings and the specifications cover only the type of device without restrictions as to details.

### **5.3.18 INDEMNIFICATION**

**5.3.18.1** To the fullest extent permitted by law, the Contractor shall defend, indemnify and hold harmless the District, its agents, officers and employees, from and against any and all claims, damages, liability, judgments, demands, losses and expenses, including, but not limited to, attorneys' fees and costs including consultants' fees, for damage to property of any kind whatsoever including the loss of use thereof, and to whomever belonging, including Contractor, and/or for injury to or death of any person or persons, including employees for Contractor or subcontractor of any tier. Such indemnity shall apply to any conduct arising out of or in any way connected with the acts or omissions, willful misconduct or negligent conduct, whether active or passive, of Contractor, Contractor's agents or employees including subcontractors and their agents and employees, arising and/or relating directly or indirectly out of the obligations undertaken in this Contract, including the performance of Work under the Contract by Contractor, Contractor's agents or employees. This indemnity shall

further apply to including subcontractors and their agents or employees, products installed and/or furnished on the Project by Contractor, Contractor's agents or employees including subcontractors and their agents, or arising from the use of the premises, facilities or services of the District, its agents, officers or employees, save and except claims or liability arising through the sole negligence, willful misconduct or active negligence (as provided by California Civil Code section 2782) of District, its agents, officers or employees, and Contractor shall reimburse District for any expenditures, including reasonable attorneys' fees and costs, which District may incur by reason of such indemnified matters and, if requested by District, Contractor shall defend any such lawsuit, matter or proceeding at the sole cost and expense of the Contractor. Failure to defend immediately may, at the sole discretion of the District, be grounds for termination or suspension by the District of the Contract as provided herein. Such indemnity shall also extend to claims, damages, liabilities, judgments, demands, losses and expenses or injuries occurring after completion of the Project as well as during the Work's progress.

**5.3.18.2** In addition to the foregoing, the Contractor shall defend, indemnify and hold harmless the District, its agents, officers and employees, from and against any and all claims, damages, liability, judgments, demands, losses and expenses, including but not limited to, attorneys' fees and costs (including consultants' fees), to which the District may be subject as a result of the non-completion of the Contract which negatively affects separate contractors on adjoining or overlapping work. The obligations set forth in this subparagraph and subparagraph 5.3.18.1, above, are not limited by, but are in addition to, the performance bonds required by this Contract.

**5.3.18.3** In the event Contractor or Contractor's insurance carrier fails or refuses to accept the tender of defense of a claim by the District or any other such claim exceeds the limits of the Contractor's insurance limits, District shall have the right to estimate the amount of damage to third parties to which the District may be liable and any estimated amounts for attorneys' fees and costs to defend itself, and to cause the Contractor to pay same, and the amount due the Contractor under this Contract, or the whole or so much of the money due or to become due to



the Contractor under this Contract as may be considered necessary by the District, shall be retained by the District until such suit or claim for damages, or other remedy shall have been settled or otherwise disposed of and satisfactory evidence to that effect is furnished the District. The District's election to exercise or not exercise rights pursuant to this provision shall be in addition to any common law rights which the District may possess.

### **5.3.19 ASSIGNMENT OF CONTRACT**

**5.3.19.1** The Contractor shall not assign this Contract or any rights or duties herein without the prior written consent of both the District and the surety in each instance; provided, however, that the Contractor may, with the consent of District and surety, make an assignment of any sums of money due or to become due under this Contract as collateral for financial purposes in connection with the Contract.

**5.3.19.2** Any such assignment shall contain a clause in the instrument of assignment to the effect that it is agreed that the funds to be paid the assignee under the assignment are subject to all liens or claims of any kind whatsoever authorized by law, whether prior or subsequent, for services rendered or materials supplied for the performance of the Work called for in the Contract in favor of all persons, firms or corporations rendering such services or supplying such materials.

### **5.3.20 ANTITRUST CLAIMS**

**5.3.20.1** These provisions are included in this Contract as required by California law:

**5.3.20.1.1** In entering into a public works Contract or a subcontract to supply goods, services or materials pursuant to a public works contract, the contractor or subcontractor offers and agrees to assign to the District all rights, title and interest in and to all causes of action it may have under Section 4 of the Clayton Act (15 U.S.C. section 15) or under the Cartwright Act (Chapter 2 [commencing with Section 16700] of Part 2 of Division 7 of the Business and Professions Code), arising from purchases of goods, services or materials pursuant to the public works contract or the subcontract. This assignment shall be made and become effective at the time the District tenders final payment to the Contractor, without further acknowledgement

by the parties.

**5.3.20.1.2** In submitting a bid to the District, the Bidder offers and agrees that if the bid is accepted, it will assign to the District all rights, title and interest in and to all causes of action it may have under Section 4 of the Clayton Act (15 U.S.C. section 15) or under the Cartwright Act (Chapter 2 [commencing with Section 16700] of Part 2 of Division 7 of the Business and Professions Code), arising from purchases of goods, materials or services by the Bidder for sale to the District pursuant to the bid. Such assignment shall be made and become effective at the time the District tenders final payment to the Bidders, without further acknowledgement by the parties.

**5.3.21 BANKRUPTCY OF CONTRACTOR.** The Contractor shall immediately notify the District of its own or of any of its subcontractor's filing for bankruptcy protection and provide the District with a copy of the Bankruptcy Case Number and title of the Court in which the petition for bankruptcy was filed. Filing for bankruptcy protection shall be a default of this Contract and grounds for termination as provided by Article 5.11.

**5.3.22 CONTACT WITH MEDIA.** Contractor shall refer all media inquiries to the District's Department of Public Relations at (619) 686-6222 and shall not speak to media personnel about District projects without written permission from the District. No media personnel shall be allowed on the Work Site without written permission of the District.

### **5.3.23 CLEANING UP**

**5.3.23.1** At all times, maintain the Work Site in a neat and orderly condition. Daily, and more often if necessary, inspect the site and pick up all scrap, debris and waste material. Remove items to the place designated for their storage. Combustible waste shall be removed from the site. Flammable waste shall be kept in sealed metal containers until removed from the site. Weekly, and more often if necessary, remove from the site and dispose of all collected scrap, debris, and waste material.

**5.3.23.2** Abate nuisance dust by cleaning, sweeping, and sprinkling with water or other means as necessary.

**5.3.23.3** Weekly, and more often if necessary, inspect arrangements of materials stored on the site, restack, tidy, or otherwise service arrangements to meet the requirements specified above.

**5.3.23.4** Keep the streets in and adjacent to the construction area clean at all times. When required by the plans or specifications, the contractor shall operate a self-loading motor sweeper at least once each day for the purpose of keeping paved areas acceptably clean.

**5.3.23.4** Contractor shall be responsible for Health and Welfare of employees, trades, and the public as relates to maintaining a clean and orderly site.

## **ARTICLE 5.4 – SUBCONTRACTORS**

### **5.4.1 REQUIREMENTS AT BID**

#### **5.4.1.1 List of subcontractors:**

**5.4.1.1.1** Every Bidder shall comply with the Subletting and Subcontracting Fair Practice Act, Public Contract Code sections 4100, et seq., and shall set forth in its bid:

**5.4.1.1.1.1** The name, Contractor's state license number, and location (city and state) of the place of business for each subcontractor who will perform work or labor or render service to the Contractor in or about the construction of the Work or improvement to be performed hereunder or who, under subcontract to the Contractor, specially fabricates and installs a portion of the Work or improvement according to detailed drawings in the plans and specifications, in an amount in excess of one-half of one percent (1%) of the Contractor's total bid or, in the case of bids or offers for the construction of streets or highways, including bridges, in excess of one-half of one percent (1%) of the Contractor's total bid or Ten Thousand Dollars (\$10,000.00), whichever is greater.

**5.4.1.1.1.2** A description of the Work to be performed by each subcontractor. The Contractor shall list only one subcontractor for each portion of the Work as is defined by the Contractor in its bid.

**5.4.1.1.2** If Contractor fails to specify a subcontractor or specifies more than one subcontractor for the same portion of Work to be

performed under this Contract, Contractor agrees that it is fully qualified to perform that portion itself and that Contractor shall perform that portion itself.

### **5.4.2 SUBCONTRACTUAL RELATIONS**

**5.4.2.1** The Contractor shall require each subcontractor, to the extent of the Work to be performed by the subcontractor, to be bound to the Contractor by terms of the Contract documents and to assume toward the Contractor all the obligations and responsibilities which the Contractor, by these Contract documents, assume toward the District. Each subcontract agreement shall preserve and protect the rights of the District under the Contract documents with respect to the Work to be performed by the subcontractor so that subcontracting will not prejudice such rights. Where appropriate, the Contractor shall require each subcontractor to enter into similar agreements with sub-subcontractors. Prior to the execution of the subcontract agreement, the Contractor shall make available to each proposed subcontractor, copies of the Contract documents to which the subcontractor will be bound, and, upon written request of the subcontractor, identify the terms and conditions of the proposed subcontract agreement which may be at variance with the Contract documents. Subcontractors shall similarly make copies of applicable portions of such documents available to their respective sub-subcontractors.

**5.4.2.2** Contractor may be required to furnish the District with information as to the technical experience, financial status, location of shop, factory or plant and adequacy of the shop, factory, plant or equipment of each subcontractor identified in its proposal. The Contractor, upon the written request of the District, shall provide a copy of any subcontract entered into by the Contractor to the District for its review. The Contractor shall not begin Work until the information required herein has been provided to the District.

**5.4.2.3** The District will promptly notify the Contractor in writing if the District, after due investigation, has a reasonable objection to any such proposed subcontractor.

**5.4.2.4** The Contractor shall not Contract with a proposed person or entity to whom the District has made a reasonable and timely objection. If

the District has a reasonable objection to a person or entity proposed by the Contractor, the Contractor shall propose another to whom the District has no reasonable objection, such substitution shall be at no cost to District.

**5.4.2.5** Contractor shall include in all subcontracts and in all purchase orders a clause specifically binding the respective subcontractor and supplier to the dispute resolution provisions of these Contract documents.

## **ARTICLE 5.5 – PROTECTION OF PERSONS AND PROPERTY**

### **5.5.1 SAFETY PRECAUTIONS AND PROGRAMS**

**5.5.1.1** The Contractor alone shall be responsible for the safety, efficiency and adequacy of its plant, appliances and methods, and for any damage which may result from their failure or their improper construction, maintenance or operation. The Contractor shall be responsible for initiating, maintaining and supervising all safety precautions and programs in connection with the performance of the Work.

**5.5.1.2** The Contractor shall give notices and comply with all applicable laws and regulations of any public body having jurisdiction for the safety of persons or property to protect them from damage, injury or loss and shall erect and maintain all necessary safeguards for such safety and protection. The Contractor shall notify owners of adjacent property and of underground facilities and utilities when prosecution of the Work may affect them, and shall cooperate with them in the protection, removal, relocation and replacement of their property.

**5.5.1.3** Material usage shall be accomplished with strict adherence to California Division of Industrial Safety, or other governing regulations, and all manufacturer's warning and application instructions listed on the Material Safety Data Sheet and on the product container label.

**5.5.1.4** Payment for performing all work necessary to provide safety measures shall be included in the prices bid for other items of work except where separate bid items for excavation safety are provided.

**5.5.1.5** The Contractor shall be required to

perform any Work relating to the hazardous materials if so directed by the District.

### **5.5.2 ACCIDENT PREVENTION, BARRICADES, LIGHTS, SAFETY MEASURES AND DETOURS**

**5.5.2.1** Contractor shall provide for the protection of persons, employees, the Work and materials and equipment to be incorporated into the Work, and other property at the Work Site and adjacent thereto and shall observe the safety provisions of applicable laws, building and construction codes and safety regulations. When use or storage of explosives or other hazardous materials or equipment or unusual methods are necessary for execution of the Work, the Contractor shall exercise utmost care and carry on such activities under supervision of properly qualified personnel.

**5.5.2.2** The Contractor shall take all necessary measures to protect the Work and prevent accidents during the construction. It shall provide and maintain sufficient night-lights, barricades, guards, temporary sidewalks, temporary bridges, danger signals, watchmen and necessary appliances and safeguards to properly safeguard life and property. It shall also protect all excavation, equipment and materials with barricades and danger signals so that the public will not be endangered. It shall maintain temporary detours, if required by the Engineer, and keep same in usable condition. The Contractor shall be particularly careful in providing barricades and signalmen on any of the Work that is constructed along or in highways or streets.

**5.5.2.3** The Contractor shall designate a responsible member of the Contractor's organization as the Safety Representative whose duty shall be the prevention of accidents. This person shall be the Contractor's superintendent unless otherwise designated by the Contractor in writing to the District.

**5.5.2.4** The Contractor will be required to conduct its work so as to cause a minimum of inconvenience to District tenants holding valid permits or lease agreements. Safe entrances and exists shall be constructed and maintained for the use of such tenants at all times during construction and until final acceptance of the Work. The Contractor shall promptly provide necessary bridges across excavations for

ingress and egress to places of business or residences and shall promptly remove surplus materials from the immediate vicinity of places of business.

**5.5.2.5** Other portions of District property may be closed to traffic with the approval of the Engineer. Alternate cross streets shall be kept open at all times. Free access shall be provided at all times to all fire hydrants unless otherwise authorized by the Engineer.

**5.5.3** EMERGENCIES. In an emergency affecting safety or protection of persons or property or the Work, the District may act without notice to the Contractor and the Contractor shall act, at the Contractor's discretion, to prevent threatened damage, injury or loss, and shall promptly as conditions permit notify the insurance carrier and the District of the nature of the emergency and related circumstances. Immediately thereafter, the Contractor shall prepare a written report setting forth in detail the action taken and describing in detail all circumstances and conditions which are related to such action.

**5.5.4** CARE AND CUSTODY OF WORK/LOSS AND DAMAGE

**5.5.4.1** The Contractor shall be held responsible for, and be required to make good at its own expense, all damage to persons or property caused by Contractor or its subcontractors, agents or the employees of either of them, during the progress of the Work and until its final acceptance.

**5.5.4.2** All loss or damage to the Work arising from any unforeseen difficulties which may be encountered in the progress of the Work or from any action of the elements, fire or acts of God, or from any act or omission by the Contractor or any agent or person employed by it, shall be sustained by the Contractor. There shall be no apportionment of any such loss or damage between the District and Contractor and the fact that periodic or other type payments may be made shall not make this Contract divisible and severable, the intent of the parties being that the Contract is entire, unqualified and absolute and must be performed no matter what the cost to the Contractor. Notwithstanding the foregoing, in the event any such loss or damage is proximately caused by an act of God as defined in Public Contract Code section 7105,

Contractor shall repair or restore said loss or damage at its sole cost and expense to the extent of five percent (5%) of the full original Contract amount and perform and complete the entire Contract, provided, however, in the event such loss or damage from said cause exceeds said five percent (5%), District shall have the option to require Contractor to perform and complete the entire Contract and require the Contractor to pay at Contractor's sole cost and expense for all said loss or damage to the extent of five percent (5%) of the full Contract amount (the District to pay for the remainder of such loss or damage in accordance with Article 5.7), or the District may terminate the entire Contract. If the District exercises the option to terminate the entire Contract, Contractor shall be paid under the terms of the Contract for work actually performed prior to said loss or damage, less payments previously made, which shall constitute payment in full. Furthermore, in the event of such termination, Contractor shall be relieved from the obligation to repair or restore the loss or damage to the extent of five percent (5%) of said Contract amount and from the further obligation to perform and complete the Work.

**5.5.4.3** The Contractor shall maintain the work during construction and until acceptance. This maintenance shall constitute continuous and effective work prosecuted as required with adequate equipment and forces to the end that all parts of the work be kept in satisfactory condition at all times. All costs of maintenance during construction and before final acceptance shall be included in the price bid and the Contractor will not be paid additional amounts for such work, unless otherwise noted.

**5.5.4.4** Particular attention shall be given to drainage, both permanent and temporary. The Contractor shall use all reasonable precautionary measures to avoid damage or loss that might result from accumulations and concentrations of drainage water, and material carried by such water and such drainage shall be diverted or removed when necessary to prevent damage to excavation, embankments, surfacing, structures, or property. Suitable measures shall be taken by the Contractor to prevent the erosion of soil in all construction areas where the existing ground cover has been removed. Contractor shall prevent storm and wastewater and storm debris from reaching the

Work Site from any source to avoid damage to the Work. Contractor shall be responsible for any damage to person or property on or off the Work Site due to its operations, interrupting or diverting such storm or wastewater.

**5.5.4.5** In the event the Contractor fails to maintain the Work Site as required by this Contract, the Engineer shall notify the Contractor of such failure. If the Contractor fails to remedy the unsatisfactory maintenance within 24 hours of receipt of the notice, the Engineer may immediately proceed with adequate forces and equipment to maintain the Project and the entire cost of such maintenance will be deducted from any monies due the Contractor.

## **ARTICLE 5.6 – INSURANCE AND BONDS**

### **5.6.1 CONTRACTOR'S INSURANCE**

**5.6.1.1** No work shall be done under this Contract unless there is in effect insurance required under this section and the Supplementary Requirements and approved by the District; nor shall the Contractor allow any subcontractor to commence Work until all its insurance has been obtained and approved.

**5.6.1.2 Types of Insurance:** The Contractor shall maintain in full force and effect, for the period covered by the Contract, the following insurance:

**5.6.1.2.1** The Contractor shall maintain or cause to be maintained adequate workers' compensation insurance in accordance with California Labor Code section 3700 to secure the payment of compensation to its employees and employees of any subcontractor under it who may come within the protection of such workers' compensation laws of the State of California, and shall provide or cause to be provided employer's liability insurance for the benefit of its employees and the employees of any subcontractor under it not protected by such compensation laws.

**5.6.1.2.2** The Contractor shall take out and shall furnish satisfactory proof, by certificate or otherwise, as may be required, that it has taken out "OCCURRENCE FORM" Commercial General Liability insurance, including completed operations and Contractual liability coverage, with coverage at least as broad as Insurance Services Office Commercial General Liability

Form CG 0001, to protect said Contractor against loss from liability imposed by law from damages on account of bodily injury, including death resulting therefrom, suffered or alleged to have been suffered by any person or persons, other than employees, resulting directly or indirectly from the performance or execution of this Contract or any subcontract thereunder, and also to protect said Contractor against loss from liability imposed by law for damage to any property, caused directly or indirectly by the performance or execution of this Contract or any subcontract thereunder.

**5.6.1.2.3** Contractor shall take out and furnish satisfactory proof, by certificate or otherwise, as may be required, that it has taken out Commercial Automobile Liability insurance covering accidents arising out of the use and operation of all owned, non-owned and hired automobiles and trucks at least as broad as Insurance Services Office Form CA 0001.

**5.6.1.2.4** Where the Work includes a new structure or new structures and is not construction on an existing structure subject to loss or damage, the Contractor shall maintain or cause to be maintained Builder's Risk insurance on a complete value form sufficient to protect against such loss or damage in full until the Work is accepted by the District. Coverage shall be all risk of loss including coverage for theft or vandalism; the District shall be included as a named insured; the policy shall stipulate that losses will be adjusted with, and payable to, the District; and any deductible will be borne by Contractor.

**5.6.1.3** All liability and property damage insurance shall be maintained by the Contractor in full force and effect during the Contract Time unless otherwise set forth in the Supplementary Requirements. The amount of coverage of said insurance shall be not less than the following:

**5.6.1.3.1** Commercial General Liability covering bodily injury and property damage with combined single limits of \$2,000,000.00 per occurrence and \$2,000,000 Project Specific Aggregate.

**5.6.1.3.2** Business Auto Liability covering owned, non-owned and hired autos and trucks bodily injury and property damage with combined single limits of \$2,000,000.00.

**5.6.1.4** All said commercial general liability insurance policies shall: (1) name, or be endorsed to name, the District, its officers, officials and employees as additional insureds and protect the District against all liabilities, costs, damages, expenses and provide for the legal defense of claims and attorneys' fees and the cost thereof, (2) state, or be endorsed to state that Contractor's insurance is primary and not excess or contributing to any insurance issued in the name of the District, and (3) contain a severability of interest or cross-liability clause. The required Workers' Compensation policy shall be endorsed with a waiver of subrogation clause for the Work under this contract.

**5.6.1.5** All said policies of insurance shall have a non-cancellation clause providing that thirty (30) days' written notice shall be given to the District prior to such cancellation except for notice of cancellation for non-payment of premium which shall have a ten (10) day notice of cancellation. All such notices shall be delivered to the District's Construction Administration Department and all insurance companies must be satisfactory to the District.

**5.6.1.6** The procuring of such required policies of insurance shall not be construed to limit Contractor's liability hereunder, nor Contractor's obligations under the indemnification provisions and requirements of this Contract.

**5.6.1.7** Nothing herein contained shall be construed as limiting in any way the extent to which the Contractor may be held responsible for the payment of damage to persons or property resulting from its operations or the operations of any subcontractor under it.

**5.6.1.8** Certificates evidencing all required insurance and endorsements effecting coverage required by this clause shall be delivered to the Construction Administration Department prior to the signing of the Contract by the District and shall be in a form acceptable to the District.

**5.6.1.9** The District reserves the right to require complete, certified copies of all required insurance policies at any time.

## **5.6.2 PERFORMANCE AND LABOR AND MATERIAL BONDS**

**5.6.2.1** The Contractor shall furnish within

fourteen (14) calendar days after the Notice of Award of Contract along with an executed Contract the following bonds:

**5.6.2.1.1** The Contractor shall furnish a labor and material bond in an amount not less than one hundred percent (100%) of the estimated Contract price, to be paid to the San Diego Unified Port District, conditioned upon the payment by the Contractor for all materials, services, supplies and transportation furnished in the performance of the Work contracted to be done by the terms of said Contract, and for any work or labor of any kind done thereon by an admitted surety, as defined in Code of Civil Procedure Section 995.210, authorized to do business as such in the State of California, possess an AM Best Rating of VII or better, be listed on the Federal Registry Circular 570. Bonds shall cover the Contractor's obligations during the guarantee and/or warranty periods as well as the construction period. Bonds shall comply with California Civil Code section 3248, subdivisions (b), (c) and (d), and shall be enforceable pursuant to California Civil Code sections 3249, 3250, 3251 and 3252. California Civil Code section 3248(a) shall not apply.

**5.6.2.1.2** The Contractor shall also concurrently furnish a faithful performance bond in an amount not less than one hundred percent (100%) of the estimated Contract price, to be paid to the District, conditioned upon the faithful performance by the Contractor of all covenants and stipulations in the Contract by a surety acceptable to the District which is an admitted surety, as defined in Code of Civil Procedure Section 995.210, authorized to do business as such in the State of California, possess an AM Best Rating of VII or better, be listed on the Federal Registry Circular 570. Bonds shall cover the Contractor's obligations during the guarantee and/or warranty periods as well as the construction period.

**5.6.2.2** If, during the continuance of the Contract, any of the sureties, in the opinion of the Board, evidenced by resolution, are or become irresponsible, the Board may require additional sufficient sureties, which the Contractor shall furnish to the satisfaction of said Board, within ten (10) days after notice, and in default thereof, the Contract may be suspended by the Board evidenced by resolution, and the materials may be purchased or the Work completed as elsewhere provided in these

specifications.

**5.6.2.3** If the Contract sum is increased, the Contractor shall advise the surety of the increased amount and the performance bond and labor and materialmen's bond shall be increased accordingly.

## **ARTICLE 5.7 – CHANGES IN THE WORK**

### **5.7.1 CHANGES AND EXTRA WORK**

**5.7.1.1** Changes are alterations made to the Contract after the bids are opened, which modify the character or increase or decrease the limits of the Work, such as but not limited to, those affecting design, materials, installation, construction, shapes, dimensions, quantities, locations or schedules. The District, before the final acceptance of the Work, may order changes in the Work and may order extra materials and extra work in connection with the performance of the Contract, and the Contractor shall promptly comply and diligently carry out such orders in accordance with the Contract documents. The District reserves the right to make changes which may increase, decrease or have no effect on the amount of Work to be done or the time duration in which the work is to be performed

**5.7.1.2** A variation between estimated quantities in the bid schedule and actual quantities of work or material required to construct the Work as it is shown on the Contract documents as they exist at the time the bids are opened does not constitute a change or extra Work and does not require additional authorization and all quantities shall be paid for at the unit or lump sum prices established in the bid.

**5.7.1.3** Changes in the Work and extensions of Contract Time by reason of the change shall not in any way release any guarantees/warranties given by the Contractor pursuant to the provisions of the Contract, nor shall such changes in the Work relieve or release the sureties of bonds issued for the Work. The sureties in executing such bonds shall be deemed to have expressly agreed to any such change in the Work or increase in the Contract amount and to any extension of Contract Time.

**5.7.2 FORM OF CHANGES.** The Engineer shall have the authority to order changes in the work involving adjustment in the Contract Sum

or extension of the Contract Time and not inconsistent with the intent of the Contract documents. Such changes may be affected by written direction from the Engineer and shall be binding on the District and Contractor. The Contractor shall carry out such written orders promptly. Such written directions may be in the form of a response to a RFI, a written direction, a CCO, or in any other written form determined by the District. In the event the Contractor contends that a written direction will increase the Contract sum, it shall commence the noted Work and submit a Change Order Request, as provided in Section 5.7.3.2.4. If such Change Order Request (COR) is denied, the Contractor will not be entitled to additional compensation for Work performed pursuant to the written direction. A CCO can be of two types: A Bilateral Change that is agreed upon and signed by the District and the Contractor or a Unilateral Change that is not signed by the Contractor. All changes in the Work involving price and/or time must be authorized by CCO. Until such time as a bilateral change order is entered into concerning the District's written direction, the Contractor shall conduct the Work as Force Account Work as outlined in 5.7.3.3 and shall be subject to the same requirements found therein.

### **5.7.3 BILATERAL CHANGES**

**5.7.3.1** There are two types of Bilateral Changes: fixed price and force account.

**5.7.3.2 Fixed Price Changes:** If changes in design, workmanship, materials or time duration are of such a nature as to increase or decrease the cost of the Work, the price fixed in the Contract shall be increased or decreased by the amount as the Contractor and the District may agree upon as reasonable. Proper allowance for the increase or decrease in the cost of the Work shall be computed at the Contract rate, so far as possible. If the change involves an increase or decrease in a unit price item, the increase or decrease shall be the changed quantity multiplied by the unit price.

**5.7.3.2.1** No order for alteration, modification or extra work which shall increase or decrease the cost of the Work shall be invoiced or payable unless the resulting increase or decrease in price or Contract Time shall have been agreed upon in writing and the CCO signed by the Contractor and the District, or their agents and authorized representatives or, in the event of a

Unilateral Change Order, signed by the District.

**5.7.3.2.2** The Contractor, in its price proposals for changes in the Work that will increase the Contract amount, shall individually and specifically list its costs and use percentage markups as described hereinafter. The Contractor shall require its subcontractors to do the same, and the subcontractors' price proposals shall accompany the Contractor's price proposals.

**5.7.3.2.3** The Contractor shall upon request of the District permit inspection of the original unaltered bid estimate, subcontract agreements and purchase orders relating to the change and documents substantiating all costs associated with the cost proposal.

**5.7.3.2.4** The Contractor shall submit a Change Order Request ("COR") on Form 9, Appendix A, within fifteen (15) calendar days, or sooner if so requested based on schedule restrictions, upon receipt of a Request for Proposal ("RFP") or a written direction from the District. Any COR by the Contractor shall include a complete breakdown of costs of both credits and extras itemizing materials, labor, taxes, overhead and profit on a form approved by the District. Subcontract Work shall be so indicated and written proposals for subcontractors shall be included with similar breakdowns furnished. Following submissions of cost breakdowns, the Contractor shall meet with the District if requested to discuss all aspects of the scope, costs, scheduling and construction methods, to ensure agreement.

**5.7.3.2.5** If the Contractor fails to timely submit the COR, the District has the right to order the Contractor in writing to commence the Work immediately on a Force Account Change Order basis or a Unilateral Change Order to the Contract price in accordance with the District's estimate of cost. If the change is issued based on the District's estimate, the Contractor waives its right to dispute the action unless within fifteen (15) calendar days following completion of the specified added or deleted Work, the Contractor presents written proof that the District's estimate was in error.

### **5.7.3.3 Force Account Change Order**

**5.7.3.3.1** In the discretion of the District for any reason, a Force Account Change Order may fix

a maximum price which shall not be exceeded unless authorized by the District in writing, and subject to such limitation, such alteration, modification or extra shall be paid for at the actual necessary cost as determined by the sum of the following items in Subparagraphs 5.7.3.3.1.1 through 5.7.3.3.1.6, inclusive, and as further defined as Subsection 5.7.5:

**5.7.3.3.1.1** Prevailing wage or actual rate paid to workers.

**5.7.3.3.1.2** Markup for labor burden, including premium on compensation insurance and charges for social security taxes and other taxes pertaining to labor and the proportionate cost of premiums of public liability, property damage and other insurance applicable to the extra work involved and required by the Contract for off site work and auto only.

**5.7.3.3.1.3** Materials, including sales tax and other applicable taxes pertaining to materials.

**5.7.3.3.1.4** Plant and equipment rental, at rates previously agreed to or required by the Contract. No charge for the cost of repair to plant or equipment will be allowed and equipment items having a capital cost of under Five Hundred Dollars (\$500.00) are considered small tools and are included in the stipulated markup percentages for overhead and profit.

**5.7.3.3.1.5** Markup for overhead and profit is limited in these General Conditions. Special attention is directed to 5.7.5.1.1, in these General Conditions.

**5.7.3.3.1.6** The proportionate actual costs for bonds required in accordance with these General Conditions.

**5.7.3.3.2** The District reserves the right to furnish such materials as it may deem expedient and no allowance will be made for profit thereon.

**5.7.3.3.3** Whenever any Force Account Change Order Work is in progress, the amount, but not the price, of all extra Work performed shall be entered by the Contractor upon report sheets furnished by the Engineer (see Form 1, "Time and Materials Report," Appendix A) and signed by both parties on the date the particular Work is performed, which daily reports shall be the true record of extra Work done. No claim for compensation for such extra Work will be



allowed unless such report shall have been made by the Contractor daily and countersigned by the District's representative. It is the Contractor's responsibility to obtain the District representative's countersignature.

**5.7.3.3.4** In the event the Contractor and the District reach a negotiated, signed agreement while the work is proceeding under a Force Account, the Contractor's signed written daily reports shall be discontinued and all previously signed daily reports shall become invalid for purposes of payment.

**5.7.3.3.5** The Contractor shall bear all of its costs of administering Force Account Change Orders. These costs are considered included within the markup for overhead and profit referenced above.

**5.7.3.3.6** The Contractor shall at all times during the performance of the contract prosecute the Force Account Change Order work with such forces and equipment as, in the opinion of the District, are appropriate to complete the different portions of the work in the order required and within the specified time and to secure a satisfactory quality of work.

**5.7.4 UNILATERAL CHANGE ORDERS.** If the District and the Contractor fail to agree as to a Bilateral Change Order, if adequate cost information is not provided as required, or for any other reason whatsoever in the discretion of the District, the Contractor shall proceed immediately with the changed Work upon receipt of a Unilateral Change Order or written direction from the District. If the Contractor disputes the Unilateral Change Order or written direction, the Contractor may make a claim as required by this Contract but shall be obligated to conduct the Work addressed by the Unilateral Change Order or written direction.

#### **5.7.5 PRICING FOR ALL TYPES OF CHANGES**

**5.7.5.1** The following limitations shall apply in the calculation of the costs of changes in all changed work:

##### **5.7.5.1.1** Markups for Overhead and Profit:

**5.7.5.1.1.1** For Work performed by the Contractor shall equal a maximum of fifteen percent (15%) of the direct cost (as defined

herein) unless Contractor's overhead is stipulated as a daily rate in the bid schedule, in that event, the bid daily rate shall apply.

**5.7.5.1.1.2** For Work performed by a subcontractor of any tier shall equal a maximum of fifteen percent (15%) of its direct costs (as defined herein). Both the Contractor and subcontractor shall receive a five percent (5%) markup on the total cost of their respective subcontractors.

**5.7.5.1.1.3** In no case shall the markup exceed twenty-five percent (25%) of the direct cost as described in Subparagraphs 5.7.5.1.1.1 and 5.7.5.1.1.2, above, regardless of the number of Contract tiers actually existing.

**5.7.5.1.1.4** For deleted Work of any Contract tier described in 5.7.5.1.1.1 through 5.7.5.1.1.3 above, the credit markup shall be ten percent (10%). For deleted Work, neither the Contractor nor subcontractor shall be allowed a positive markup on their respective subcontractor to administer the credit Change Order.

**5.7.5.1.1.5** Where the total direct cost of a Change Order exceeds Fifty Thousand Dollars (\$50,000.00), the markup for the affected Contract tiers, as provided in Subparagraphs 5.7.1.1 and 5.7.1.2 herein shall be reduced from fifteen percent (15%) to ten percent (10%). All other markup percentages shall remain unchanged.

**5.7.5.1.1.6** The markup for overhead and profit for the Contractor and subcontractors of any tier shall be considered to include insurance required by the Contract of the Contractor other than mentioned herein, field and office supervisors, salaries for project managers, engineers, superintendent, timekeeper, storekeeper and secretaries, assistants, inspectors, watchmen, use of small tools, consumables, incidental job burdens and general field and home office expenses, including the preparation of Change Orders, and no separate allowance will be made thereof. Payment for markup, which includes overhead and profit, shall constitute satisfaction of all costs incurred as a result of performing the Change Order work. Incidental job burdens include, but are not limited to, office equipment and supplies, computer services, small tools, reproduction costs and services, temporary toilets, telephone, facsimile, office personnel and

conformance to regulatory requirements. Items such as, but necessarily limited to, review and coordination, estimating, recording, detailing, engineering and expediting relative to Contract changes are associated with field and office supervision and are considered to be included in the Contractor's markup percentages for profit and overhead.

**5.7.5.1.1.7** The mark-up for overhead and profit for the Contractor and subcontractors of any tier shall not include the actual cost of scheduling services required for the preparation of the time impact evaluation resulting from excusable and compensable delays. The fully burdened rate for this work shall not exceed one hundred dollars (\$100) per hour.

**5.7.5.1.2 Direct costs:**

**5.7.5.1.2.1** Direct costs for the purposes of markup shall include basic rates for labor and the actual cost to the Contractor for the equipment and materials directly required for the performance for the changed Work. Direct costs shall not include any employer payments to or on behalf of the workers for health, welfare, vacation and similar purposes.

**5.7.5.1.2.2** Unless otherwise agreed in writing, labor rates will not be recognized nor owing when in excess of those prevailing in the locality at time the Work is being performed. Premium and/or overtime rates shall not be paid by the District unless specifically authorized or directed by the District in writing. The costs for all supervision, including general superintendents and foremen, shall be included in the markups established by the Contract. The only exception to this may be working foreman who performed actual manual labor or superintendents in excess of Contract Work, in the discretion of the Engineer. No labor charges will be accepted for engineering or proposal preparation. These costs shall be included in the markups established by the Contract. If not previously submitted, a breakdown of the payroll rates for each trade shall be furnished for all Change Orders within fifteen (15) days after issuance of a notification to commence with the change order work, including the base rate and labor burden, including but not limited to benefits, payroll taxes and insurance.

**5.7.5.1.2.3 Equipment Costs:** The allowance for

equipment costs (both rental as well as Contractor-owned equipment) shall not exceed that as recommended by the rental rates established by the Rental Rate Blue Book.

**5.7.5.1.2.3.1** In computing the hourly rental of equipment, any time less than thirty (30) minutes shall be considered one-half (1/2) hour. No payment will be made for time while equipment is inoperative due to breakdown or for non-workdays. Whenever equipment is ordered by the Engineer to be held on the Work on a standby basis, or when the District is obligated for other reasons to pay for idle equipment, the rate will be seventy five percent (75%) of the rental rate with no allowance for operating costs. Standby or idle time cannot exceed eight (8) hours per day and will not be allowed for Saturday, Sunday, or holidays. Non-operating time for equipment required for account work is not considered standby or idle time if the equipment is operated and used at least once during each working day. In addition, the rental time shall not include the time required to move the equipment to the Work Site for rental of such equipment and to return it to the source. No mobilization or demobilization will be allowed for equipment already on site. If such equipment is not moved by its own power, then loading and transportation costs will be paid in lieu of rental time thereof. However, neither moving time nor loading and transportation costs will be paid if the equipment is used on the project in any other way than upon the changed Work.

**5.7.5.1.2.3.2** Individual pieces of equipment having a replacement value of Five Hundred Dollars (\$500.00) or less shall be considered to be small tools or small equipment and no payment will be made thereof. Small tools are part of the Contractor's markup.

**5.7.5.1.2.3.3** The amount to be paid to the Contractor for the use of the equipment as set forth above shall constitute full compensation to the Contractor for the cost of fuel, power, oil, lubricants, supplies, small tools, small equipment, necessary attachments, repairs and maintenance of any kind, depreciation, storage insurance, labor (except for equipment operators) and any and all costs to the Contractor incidental to the use of the equipment.

**5.7.5.1.2.3.4** The District shall only compensate the Contractor for equipment that is properly

operated and appropriate for the changed Work.

#### **5.7.5.1.3 Taxes and Insurance:**

**5.7.5.1.3.1** Federal excise tax shall not be included.

**5.7.5.1.3.2** State and City sales taxes and payroll taxes and insurance for auto and off-site only shall be shown separately and will be allowed on extras and shall be credited on credits. No markup for overhead and profit will be allowed on taxes and insurance.

**5.7.5.1.4 Bond Premiums.** The actual rate of bond premiums paid on the total cost of the Change Order will be allowed. No markup for overhead and profit will be allowed on bond premiums.

#### **5.7.5.1.5 Records.**

**5.7.5.1.5.1** The Contractor shall maintain its records in such a manner as to provide a clear distinction between the direct costs of extra work and the cost of the original Contract Work. This requirement pertains to CORs, Contract Change Orders and Work the Contractor considers to be potential Change Orders.

**5.7.5.1.5.2** The Contractor shall furnish within seven (7) days after issuance of Notice to Proceed a certified statement and detailed calculations from its accountant establishing the job site and pro rata home office overhead rates for itself and its major subcontractors, as determined by the District. Such shall be updated quarterly.

No oral instruction of any person whomsoever shall in any manner or degree modify or otherwise affect the terms of this Contract.

### **5.7.6 AUDIT**

**5.7.6.1** The District shall have the right to designate its own employee representative(s) or its contracted representatives with a certified public accounting firm who shall have the right to audit the Contractor's accounting procedures and internal controls of the Contractor's financial systems and to examine any cost, revenue, payment, claim or other records or supporting documentation resulting from any items set forth in the Contract documents including any insurance documents required to complete the

Alternate Bid Schedule - Insurance. Any such audit(s) shall be undertaken by the District or its representative(s) after notice and at reasonable times and in conformance with generally accepted auditing standards. The Contractor agrees to fully cooperate with any such auditor(s) and shall make office and support facilities available to the District's representative(s) as may be reasonably necessary to complete any such audit(s) and inspections.

**5.7.6.2** This right to audit shall extend during the length of the Contract and for a period of three (3) years or longer, if required by law, following the date of final payment. The Contractor agrees to retain all necessary records/documentation for the entire length of this audit period.

**5.7.6.3** The Contractor will be notified in writing of any exception taken as a result of any audit. Any adjustments and/or payments which must be made as a result of any such audit or inspection of the Contractor's invoices and/or records shall be made within thirty (30) days from presentation of the District's findings to the Contractor. If the Contractor fails to make such payment, the Contractor agrees to pay interest, accruing monthly, at the rate of ten percent (10%) per annum. Interest will be computed from the date of written notification of exception(s) to the date the Contractor reimburses the District for any exception(s).

**5.7.6.4** If an audit inspection or examination discloses overcharges (of any nature) by the Contractor to the District in excess of one percent (1%) of the value of that portion of the Contract that was audited, the actual cost of the audit shall be reimbursed to the District, in addition to any other remedies allowed by law.

**5.7.6.5 Subcontractor Audit Clause.** The Contractor shall include a clause in its agreement with subcontractors reserving the right for audits to be performed by its representatives from or agents of the District, who shall have the right to audit the accounting procedures and internal controls of the financial systems and to examine any cost, revenue, payment, claim, other records or supporting documentation resulting from any items set forth in its agreement including any insurance documents required to complete the Alternate Bid Schedule - Insurance. This right shall

extend during the length of this Contract and for a period of three (3) years or longer if required by law, following the date of final payment to the Contractor. The Contractor shall require its subcontractors to agree in writing to retain all necessary records/documentation for the entire length of this audit period.

## **ARTICLE 5.8 – TIME**

### **5.8.1 PROGRESS AND COMPLETION**

**5.8.1.1** Unless otherwise specified, the Contractor shall commence the Work on or before seven (7) calendar days from the date of issuance of the Notice to Proceed or the date specified within the Notice to Proceed (the "Notice to Proceed Date") and shall diligently prosecute the Work to its completion. A Notice of Completion shall be recorded for the Work, but the District's failure to do so, timely or otherwise, shall not be raised as a defense to the untimely assertion of any rights by Contractor, its subcontractors or suppliers of any tier.

**5.8.1.2** The continuous prosecution of the Work by the Contractor shall be subject only to the delays defined in this Contract. The start of Work shall include attendance at pre-construction conferences, preparation and submittal of submittals, equipment lists, and schedule of values, schedules, requests for substitutions and other similar activities. Submittals shall be prepared in accordance with the Contract documents and shall be made in the time limits indicated. Except as specifically authorized by the District, no Work shall commence on site before the Notice to Proceed Date or after the Notice to Proceed Date but before all applicable Contract requirements have been satisfied. The Contract Time shall begin on the Notice to Proceed Date.

**5.8.1.3** The Work shall be brought to completion, as determined by the District, in the manner provided in the Contract documents and in the number of calendar days set forth in the Supplementary Requirements (Contract Time).

**5.8.1.4** The Contractor shall allow for the following review time periods: RFIs, seven (7) calendar days; submittals, 21 calendar days; substitution requests, 45 calendar days.

**5.8.1.5** Failure to reach completion as

determined by the District within the Contract Time and in the manner required by the Contract documents shall subject the Contractor to liquidated damages as stipulated in the Supplementary Requirements and General Conditions unless extensions of time are granted in accordance with these General Conditions.

**5.8.1.6** The Contractor shall at all times keep on the premises sufficient material and employ sufficient supervision and workers to prosecute the Work at a rate necessary to reach completion of the Work required within the Contract Time and in accordance with the initial Contract schedule. Work shall not start nor shall the Work be left in an incomplete state for an indeterminate period of time, while equipment and materials are in transit.

**5.8.1.7** It shall be the responsibility of the Contractor to maintain its schedule so as not to delay the progress of the Work or the schedules of other contractors and workers who may be employed by the District on any Work in the vicinity of the Work to be done pursuant to this Contract, and it shall conduct its operations so as not to interfere with the Work of such contractors or workers. The Contractor is required by virtue of this Contract to cooperate in every way possible with other contractors or workers in order to complete the Work within the Contract Time. Except as otherwise provided, no additional compensation will be paid for such cooperation. If the Contractor delays the progress of the Work or the progress of other contractors or workers, it shall be the responsibility of the Contractor to take some or all of the steps outlined below to improve its progress. See Subsection 5.3.15.

**5.8.1.8** If, in the opinion of the District, the Contractor falls behind with the Work or current update of the Contract schedule and is not entitled to an extension of time, the Contractor shall take some or all of the steps outlined below to improve its progress at no additional charge to the District, and shall submit operation plans to demonstrate the manner in which the desired rate of progress may be regained.

**5.8.1.8.1** Increase construction personnel in such quantities and crafts as will substantially eliminate the backlog of Work and allow the Contractors to complete the Work within the Contract Time.

**5.8.1.8.2** Increase, when permitted, the number of working hours per shift, shifts per working day, working days per week or the amount of construction equipment or any combination of the foregoing, sufficient to substantially eliminate the backlog of Work.

**5.8.1.8.3** Reschedule activities to achieve maximum practical concurrence of accomplishment of activities; and/or

**5.8.1.8.4** Expedite delivery of materials and equipment.

**5.8.1.9** Should the Contractor at any time during the progress of the Work, refuse, neglect or be unable for avoidable reasons to supply sufficient material, supervision or workers to prosecute the Work at a rate necessary to complete the Work within the Contract Time or in accordance with the currently accepted updated construction schedule, the District shall have the right to terminate the Contract or it may give the Contractor written notice, specifying the default and requiring its correction as provided in Subsection 5.2.2. If the Contractor does not comply with a notice or termination from the District within the time specified in the notice, the District shall have the right to provide the materials and workers to finish the Work and/or terminate the Contract. The expenses incurred by the District to complete such Work shall be deducted from any monies due or which may become due under the Contract and/or the construction fund for the Work. In the event the expenses incurred exceed the amounts due to the Contractor of the construction fund for the Work, the Contractor or its surety shall reimburse the District for any such shortage in funds.

**5.8.1.10** The Contractor shall submit to the Engineer when the project is fifty percent (50%) complete, a list of proposed maintenance and instruction manuals and the scheduled dates of all required field instruction to be provided by the Contractor of the manufacturer's representatives. Copies of the maintenance and instruction manuals must be furnished to the Engineer at least two weeks prior to the scheduled dates of any required Contractor furnished field instructions or at least one month prior to project completion, if no Contractor-furnished field instructions are required.

## **5.8.2** LIQUIDATED DAMAGES

**5.8.2.1** The Contractor and District agree that the date of beginning and the time for completion as specified in the Contract of the Work to be done hereunder are ESSENTIAL CONDITIONS of this Contract and that the District will suffer financial loss in the form of lost revenues, contract administration expenses (including project management and consultant's expenses), delay and/or loss of public use if the Work is not completed within the Contract Time; and it is further mutually understood and agreed that the Work embraced in this Contract shall be commenced on the Notice to Proceed date as defined by this Contract. The Contractor agrees that said Work shall be prosecuted regularly, diligently and uninterruptedly at such rate of progress as will insure full completion within the Contract Time. It is expressly understood and agreed by and between the Contractor and the District that the time for the completion of the Work is a reasonable time for its completion, taking into consideration the average climatic range prevailing in the locality.

**5.8.2.2** If the Contractor shall neglect, fail or refuse to complete the Work within the Contract Time or any portion of the Work as indicated by Contract Time milestone, or any proper extension granted by the District, then the Contractor agrees, as a part consideration for the awarding of this Contract, to pay to the District the daily amount specified in the Supplementary Requirements and/or Technical Specifications of the Contract, not as a penalty but as liquidated damages for such breach of Contract, for each and every calendar day that the Contractor shall be in default after the Contract Completion Date or Contract Time milestone. Liquidated damages shall not be assessed when the delay is due to excusable causes beyond the control of and without the fault or negligence of the Contractor, including acts of the District, as defined in Subsection 5.8.3 below.

**5.8.2.3** The liquidated damages amount is fixed and agreed upon by and between the Contractor and the District because of the impracticability and extreme difficulty of fixing and ascertaining the actual damages the District would in such event sustain, and the amount is agreed to be the amount of damages which the District would sustain and the amount shall be retained from time to time by the District from current periodical estimates. Contractor and the District also recognize the delays, expense and

difficulties involved in the calculation and proof of the actual loss suffered by the District if the Work is not completed on time. Accordingly, instead of requiring such proof, the District and Contractor agree that the amount of Liquidated Damages specified in Supplementary Requirements and/or Technical Specifications, which amount shall be presumed to be the damages suffered by the District resulting from the delay in completion of the Work. It is agreed that the amount of liquidated damages to be paid by the Contractor for failure to complete the Work within the Contract Time shall be in the daily amount as set forth in the Supplementary Requirements and/or Technical Specifications. The Contractor specifically agrees at the time of Contracting that the amount of liquidated damages is manifestly reasonable under the circumstances for this Work.

**5.8.2.4** It is further agreed that time is of the essence of each and every portion of this Contract and of the specifications wherein a definite and certain length of time is fixed for the performance of any act whatsoever; and where under the Contract an additional time is allowed for the completion of any Work, the new time limit fixed by such extension shall be of the essence of this Contract. Beneficial occupancy of the Work or partial utilization of the Work by the District prior to completion of the Work does not waive the Contract completion date for purposes of computing and assessing liquidated damages. In addition, any applicable warranty periods do not begin to accrue until completion and acceptance of the work by the District.

**5.8.2.5** If specified in the Supplementary Requirements, the District may make a payment of extra compensation to the Contractor, as a bonus, for completion prior to the Contract completion date.

### **5.8.3 DELAYS AND EXTENSIONS OF TIME**

#### **5.8.3.1 Delays:**

##### **5.8.3.1.1 Excusable Delays:**

**5.8.3.1.1.1** Excusable delay is an interruption of the Work beyond the control of the Contractor and which interruption the Contractor could not have avoided by the exercise of care, prudence, foresight and diligence. A Contractor experiencing an excusable delay will be entitled to a Contract Time extension but will not be

entitled to additional costs. Such delays include and are limited to acts of God; acts of the public enemy; unreasonable or unusual adverse weather conditions, fires, floods, windstorms, tornadoes, wars, riots, insurrections, epidemics, quarantine restrictions, strikes, lock-outs, labor shortages caused by war or other Federal hindrances, fuel shortages, freight embargoes, accidents, delays caused by an injunction, judgment or other decree or order of a court of competent jurisdiction, priorities or privileges established for the manufacture, assembly or allotment of material by order, decree or otherwise of the United States or by any department, bureau, commission, committee, agent or administrator of any legally constituted public authority, the prevention of the Contractor from commencing or prosecuting the Work because of the acts of persons or entities not parties to this Contract, excepting the Contractor's subcontractors or agents or suppliers, and the inability to procure or the failure of public utility services. The duration of said excusable delays shall be limited to the extent that the commencement, prosecution and completion of the Work are delayed thereby, as determined by the Engineer.

**5.8.3.1.1.2** The Engineer may provide by resolution for extensions of time for causes other than those stated in Subparagraph 5.8.3.1.1.1, which the Contractor could not have avoided by the exercise of care, prudence, foresight and diligence.

**5.8.3.1.1.3** The Engineer may order the Contractor to suspend any Work because of climatic conditions. When delay is caused by an order given to suspend Work on account of climatic conditions, which in the opinion of the Engineer could have reasonably been foreseen, the Contractor will not be entitled to any extension of time or other compensation on account of such order.

**5.8.3.1.1.4** Delays due to adverse weather conditions will not be considered for weather conditions that could have been reasonably anticipated. Rain day delays shown in Table 1 below are to be included in the contract time limits. The Contractor's schedule will be considered to have incorporated these anticipated rain day delays. Contract time extensions due to delays caused by excessive precipitation will only be considered if the delay caused by excessive precipitation can be shown

to delay a task on the critical path; and precipitation is greater than 0.10 inches per any one day; and the number of days for rain delays is more than the average number of rain days anticipated for any given month as defined in the following table.

Table 1

MONTH	AVERAGE RAIN DAYS
January	7
February	5
March	7
April	2
May	1
June	1
July	0
August	0
September	1
October	2
November	3
December	5

**5.8.3.1.2 Inexcusable Delays:** A Contractor experiencing an inexcusable delay will not be entitled to a time extension or additional costs. Inexcusable delays in the prosecution or completion of any work shall include:

**5.8.3.1.2.1** All delays that could have been avoided by the exercise of care, prudence, foresight and diligence on the part of the Contractor; are caused by the Contractor or are directly attributable to the Contractor.

**5.8.3.1.2.2** Delays in the prosecution of parts of the Work, which may in themselves be excusable but do not necessarily prevent or delay the prosecution of other parts of the Work, nor the completion of the whole Work within the Contract Time.

**5.8.3.1.2.3** Delays arising from the interruptions occurring in the prosecution of the Work on account of the reasonable interference from other Contractors employed by the District, which do not impact the Contractor's critical path.

**5.8.3.2 Notice of Delay.** The Contractor shall promptly notify the District in writing of any anticipated delay in the prosecution of the Work, and, in any event, promptly upon the occurrence of the delay. Said notice shall constitute an application for an extension only if the notice requests such extension and sets forth the

Contractor's estimate, if feasible, of the additional time required together with a full recital of the cause of the delay relied upon. The District may take steps to prevent the occurrence or continuance of the delay and may determine to what extent the completion of the Work is delayed. The determination of the existence of any delay for which an extension of time will be granted will be based on whether such delay can be demonstrated by the Contractor to extend the Contractor's current critical path on the construction schedule or require the formulation of a new critical path. A critical path method schedule indicating the occurrence of delays along the critical path is the only method of demonstration that will be accepted by the District to document and claim delays. If notice of a delay is not submitted on or prior to seven (7) consecutive working days after the start of the occurrence of such a delay, the Contractor admits the occurrence had no effect on the length of its duration of Work, that no extension of time is necessary, and that no extension of time or extra compensation will be granted by the District or is due to the Contractor.

**5.8.3.3 No damages for Delay.** Except as otherwise provided by law or the provisions of these Contract documents, no monetary damages or compensation for any kind shall be paid the Contractor, or any subcontractor or any supplier because of delays which are not the responsibility of the District, which are reasonable under the circumstances involved and were within the contemplation of the parties. To the fullest extent permitted by law, the Contractor and all subcontractors and all suppliers waive all claims against the District, its consultants and their respective directors, officers, members, employees and authorized representatives for any loss or damage sustained by reason of delays in the Completion of the Work beyond the Contract Completion Date which are not the responsibility of the District, which delays are reasonable under the circumstances, and which delays were within the contemplation of the parties. However, an extension of time for the Completion of the work may be granted for a period equal to the period of delay, as defined in these General Conditions.

**5.8.3.4 Extensions of Time.**

**5.8.3.4.1** Should the Contractor seek an extension of time for the Completion of the Work

under these provisions, the Contractor must submit justification for the extension of the time requested and otherwise comply with all provisions of these Contract documents with respect to requests for extension of time.

**5.8.3.4.2** Neither this provision, nor any other provision of the Contract documents, is intended by the parties to be contrary to any express provision of law. The parties specifically agree, acknowledge and warrant that neither this provision, nor any other provision of the Contract documents, has for its objective, directly or indirectly, the exemption of the District, its consultants and their respective directors, officers, members, employees and authorized representatives, from responsibility for their own sole negligence, violation of the law or other willful injury to the person or property of another.

**5.8.3.4.3 Warranties.** In the event it is deemed necessary by the District to extend the time of completion of the Work, such extensions shall in no way release any guarantees/ warranties given by the Contractor pursuant to the provisions of the Contract documents, nor shall such extension of time relieve or release the sureties on the bonds executed pursuant to said provision. The sureties in executing such bonds shall be deemed to have expressly agreed to any such extension of time. The amount of time allowed in any extension of time shall be limited to the period of the delay as determined by the District. The granting of an extension of time because of delay shall in no way operate as a waiver on the part of the District of the right to collect damages or of any other right which the District is entitled.

## **ARTICLE 5.9 – PAYMENTS AND COMPLETION**

### **5.9.1 PERIODIC PAYMENTS**

**5.9.1.1** Each month there shall be paid to the Contractor a sum equal to ninety-five percent (95%) of the value of the Work (based on the schedule of values) performed up to the last day of the previous calendar month, less the aggregate of the previous payments. The monthly payments shall be made on the basis of monthly Progress Estimates (See Form 5, Appendix A) that shall be submitted by the Contractor and approved by the Engineer. Quantities used in computing partial payments shall be considered as estimates only and shall

be subject to revision in subsequent estimates. Work completed as estimated shall be an estimate only and no inaccuracy or error in said estimate shall operate to release the Contractor or any surety from damages arising from such work or from the enforcement of each and every provision of this Contract and the District shall have the right subsequently to correct any error made in any Progress Estimate for payment. Materials delivered but not incorporated or installed in the Work will not be included in Progress Estimates and/or payments unless allowed by Supplementary Requirements and/or Technical Specifications. If a Progress Estimate received from the Contractor is undisputed and properly submitted, payment shall be made within thirty (30) days after received, and if not so paid, Public Contract Code section 20104.50 may apply. If, however, the Progress Estimate (or Payment Request as denoted in Section 20104.50) is determined not to be proper or correct, the District may at its option correct the Progress Estimate and pay the amended amount or return the Progress Estimate no later than seven (7) days after receipt, accompanied by a document setting forth in writing the reasons it is not proper. The number of days available to make payment without incurring interest shall be reduced by the number of days the District exceeds the seven (7) day return requirement. Improper or incorrect payment estimates include, but are not limited to: the amount invoiced is inconsistent with the Contract; the estimate or performance under the Contract is in dispute and the Contractor has failed to otherwise comply with the Contract requirements; the item or services have not been accepted; the quantity of items delivered is less than the quantity invoiced; the items or services do not meet the quality requirements of the Contract; proper backup documentation for changed work was not attached to the estimate.

**5.9.1.2** Notwithstanding any other provision in this Contract, as provided in Public Contract Code section 22300 and subject to the requirements thereof, Contractor may substitute securities for monies withheld by the District to ensure proper performance under this Contract. The substitution of securities or the deposit of the amount retained shall be at the sole expense of and request of Contractor.

**5.9.1.3** The Contractor shall pay each subcontractor, materialmen and/or supplier in the time periods required by law.



## **5.9.2 APPLICATIONS FOR PAYMENT (PROGRESS ESTIMATES)**

**5.9.2.1** In Contracts with a duration of sixty (60) days or longer, on or before the 15<sup>th</sup> day of each calendar month, the Contractor shall submit to the Engineer a Progress Estimate of the value of work done and materials used to the last day of the previous calendar month. Progress Estimates shall be made in the form of itemized invoices in duplicate on a form provided by the District (see Form 5, "Progress Estimate," Appendix A) and shall be submitted together with the data set forth below:

**5.9.2.1.1** A detailed estimate of work completed to date including items of Work, unit price and total value of completed Work for each item of the proposal.

**5.9.2.1.2** A recapitulation showing balance due current month as follows:

Basic Contract Work Completed to Date	xxx
Change Order Work Completed to Date	xxx
Gross Value of Work Completed to Date	xxx
Less 5% Retention	xxx
Gross Value to Date Less Retention	xxx
Less Previous payments	xxx
Balance Due This Estimate	xxx
Less Deductions (e.g., stop notices, liquidated damages)	xxx

**5.9.2.2** Contractor warrants that upon submittal of the Progress Estimate that all work for which previous Progress Estimates have been made and payments received from the District shall, to the best of the Contractor's knowledge, information and belief, be free and clear of claims, security interests or encumbrances in favor of the Contractor, subcontractors, material suppliers or other persons, or entities making a claim by reason of having provided labor, materials and equipment related to the Work and that all work for which payment is demanded has been performed in accordance with the Contract and that the amount claimed is due. With each Progress Estimate, Contractor shall certify that the as-built drawings have been updated and jointly reviewed with the District for the month that payment is requested. (see Form 3, "As-Built Drawing Certification Form", Appendix A)

**5.9.2.3** Beginning with the second Progress Estimate, each Progress Estimate shall include

an affidavit of Contractor stating that all previous progress payments received on account of the Work have been applied on account to discharge Contractor's legitimate obligations associated with prior Progress Estimates.

**5.9.2.4** Contractor agrees to furnish, if and when required by District, receipts, vouchers, releases and/or waivers of claims for labor, material, equipment and services performed by Contractor and any and all subcontractors performing Work or furnishing materials under this Contract or any subcontract with Contractor, all in a form satisfactory to District, and it is agreed that no payment shall be made except at District's option until and unless such receipts, vouchers or releases and/or waivers, or any and all of them, have been furnished. Any progress payment made prior to acceptance of the Work by District shall not be construed as evidence of acceptance of any part of Contractor's Work.

## **5.9.3 ACCEPTANCE AND PAYMENT**

**5.9.3.1** When the Contractor considers the Work complete, it shall request in writing a final inspection. Upon inspection and acceptance by the District, a Punch List of items that are not in accordance with the Contract documents or otherwise complete will be prepared and furnished to the Contractor. At the direction of the District, the District may withhold from the final payment up to one hundred and fifty percent (150%) of the value of the Work to be completed or corrected. Upon acceptance of those Punch List items, the retained amount shall be released or, in the case of retention held in escrow, approval given to release the funds.

**5.9.3.1.1** Acceptance of the Work on behalf of the District shall occur upon the recordation of a Notice of Completion. To the extent permitted by law, such acceptance shall not constitute a waiver by the District of guarantees provided by the Contractor or "completion" as defined by Public Contract Code section 7107. When the Work has been accepted, there shall be paid to the Contractor a sum equal to ninety-five percent (95%) of the Contract price.

**5.9.3.1.2** To the extent permitted by law, the Work shall not be "complete" and the final five percent (5%) shall not become due and payable until all Punch List items are completed and accepted by the District, all final paper work required by Contract documents of the

Contractor is submitted including, but not limited to, certified payrolls, completed Record Drawings, certification of record drawings, and an executed final Release of Claims against the District in a form provided or approved by the District, provided, however, said release(s) may specifically exclude disputed Contract claims.

**5.9.3.2** Final payment of the Contract price shall include full compensation to the Contractor for all labor, materials (except as otherwise expressly provided herein), equipment use and expense required for or incidental to the completion of the Work in accordance with the drawings and specifications and to the satisfaction of the Engineer. Acceptance by the Contractor of the final payment shall constitute a waiver of all claims against the District arising under the Contract documents except those previously made in writing and identified by the Contractor as unsettled at the time of the final pay request.

**5.9.3.3** In case of suspension of the Contract, any unpaid balance shall be and become the sole and absolute property of the District to the extent necessary to repay to the District any excess in the cost of the Work above the Contract price.

**5.9.3.4** Any Punch List items shall be completed in good faith and within thirty (30) days or ten percent (10%) of the Contract Time Period, whichever is greater. Final payment shall not be due and owing until all Punch List items have been completed and accepted by the District. Failure to complete all Punch List items within the prescribed time period shall be a default of the Contract. The District reserves the right to perform Punch List Work and to back charge the Contractor for the actual cost to perform the Work plus any attendant administrative charges.

#### **5.9.4 PARTIAL UTILIZATION AND BENEFICIAL OCCUPANCY**

**5.9.4.1** The District shall have the right to utilize or place into service any item of equipment or other usable portion of the Work that is substantially complete prior to completion and acceptance of all the Work. Whenever the District plans to exercise said right, the District will perform an inspection and formulate a punchlist of unfinished work, the Contractor will then be notified in writing with a Notice of Partial Utilization signed by the Engineer identifying the

specific portion of the Work to be utilized or otherwise placed into service and a copy of the punchlist of unfinished work.

**5.9.4.2** The District shall have the right to take control of the entire Work if it is substantially completed. Whenever the District plans to exercise said right, the Contractor will be notified in writing with a Notice of Beneficial Occupancy and a copy of the punchlist of unfinished work.

**5.9.4.3** The Contractor understands that until a Notice of Beneficial Occupancy or Notice of Partial Utilization is issued or plant start up begins, all responsibility for the care and maintenance of all of the Work shall be the responsibility of the Contractor. Upon issuance of any Notice of Beneficial Occupancy or Notice of Partial Utilization the District will accept responsibility for the protection and maintenance of all such items or portions of the Work described in the written notice except for those items included on the accompanying punchlist. The Contractor shall retain full responsibility for the completion of all of the Work, regardless of whether a portion of the Work has been partially occupied or utilized by the District. The Contractor shall not refuse to allow the District to partially utilize or beneficially occupy the Work.

**5.9.4.3** The District may follow the provisions of Public Contract Code section 9203 in Beneficial Occupancy or Partial Utilization circumstances or in circumstances where the Contract work is clearly divisible.

#### **5.9.5 QUANTITY UNITS, PAYMENTS AND MEASUREMENTS**

**5.9.5.1** Quantity Units. The quantity units, such as tons, square feet, cubic yards and other units listed in the proposal, shall be the basis for payment. All Work to be paid for at the Contract price per unit of measurement will be measured by the Engineer in accordance with United States standard measures.

**5.9.5.1.1** The Contractor shall accept the compensation as provided by the Contract unit prices and by measurement and/or Contract lump sum prices as full payment for furnishing all supervision, labor, materials and equipment to perform all Work shown on the plans and specified herein, and for all expenses, loss, damage or risk of every description connected with the prosecution of the Work.

**5.9.5.2 Area and Linear Measurements.** Unless otherwise indicated on the plans and/or specified in Supplementary Requirements and/or Technical Specification, area and linear measurements of surface or underground improvements shall be made horizontally.

**5.9.5.3 Earthwork.** Quantity of earthwork within the limits indicated on the plans and/or specified in Supplementary Requirements and/or Technical Specifications may be computed in cubic yards by the method of average end areas and centerline distances. Correction for curvature may not be applied to quantities within the roadway prism as indicated on the cross sections. The Engineer shall make the computation of the quantity by the method which, in its opinion, is best suited to obtain accurate results.

**5.9.5.4 Concrete:** When payment for concrete is on the basis of cubic yards, it will be measured by certified weighmaster delivery tickets as proscribed by Business and Professions Code section 12700, et seq., or other applicable law. At the discretion of the Engineer, volumes may be verified by measurement of dimensions shown on the plans or such other dimensions as determined by the Engineer.

**5.9.5.5 Asphalt Concrete and Cement Treated Base:** When payment for asphalt concrete or cement treated base is on the basis of tons and the price includes the cost of placing asphalt concrete or cement treated base as pavement, and the completed pavement exceeds the thickness specified, then the computed weight of the asphalt concrete or cement treated base in the excess thickness up to but not exceeding one-fourth (1/4) inch, will be included in payment quantity.

**5.9.5.6 Weight – Measurements:** Weight measurements shall be in pounds or tons consisting of 2,000 pounds avoirdupois. Unless otherwise specified, material paid for by weight shall be weighed on platform scales furnished by the Contractor or on public scales. Scales furnished by the Contractor shall be satisfactory to the Engineer and shall be inspected and sealed by a representative of the State Division of Weights and Measures as often as the Engineer may deem necessary to insure their accuracy. The Contractor shall furnish to the Engineer on the date the materials are delivered to the Project licensed weighmaster's original

certified weight tickets for each load.

**5.9.5.6.1** If the material is shipped by rail, the car weights will be accepted provided the actual weight only of material will be paid for and not the minimum car weight used for assessing freight tariff, and provided further that car weights will not be acceptable for material to be passed through mixing plants.

**5.9.5.6.2** Trucks used to haul material being paid for by weight shall be weighed empty daily at such times as Engineer directs, and each truck shall bear a plainly legible identification mark. Full compensation for all expense involved in measuring and weighing shall be included in the prices bid, and no additional payment will be made therefor.

**5.9.5.6.3** Quantities of material wasted or disposed of in a manner not called for under this Contract, or rejected loads of material, including material rejected after it has been placed, material not unloaded from vehicles, material placed outside the plan lines or material remaining on hand after completion of the Work, will not be paid for and such quantities will not be included in the final total measured quantities. No compensation will be allowed for disposing of rejected or excess material.

**5.9.5.6.4** Unless otherwise specifically provided, when mineral aggregate, imported borrow or other specified roadway material is being paid for on a weight basis, the weight of material to be paid for will be determined by deducting from the weight of material delivered to the Work, the weight of water in the material at the time of weighing, in excess of six percent (6%) of the dry weight of the material, except that when the material is to be bituminous treated, deduction will be made for the weight of water in excess of three percent (3%). No compensation or other allowance will be made for the weight of such water deducted. The procedure followed for the determination of water shall be in accordance with the "Standard Method for Determination of Moisture of Volatile Distillates in Bituminous Mixtures" of the American Association of State Highway Officials, Serial Designation T-110-42, with the exception that commercial xylene shall be used as the solvent and the percentage of water shall be expressed on the basis of the dry weight of the material according to the following formula:

% Water = 
$$\frac{\text{Volume of water in trap in milliliters}}{\text{Weight of wet samples in grams}} \times 100$$

## ARTICLE 5.10 – CLAIMS AND DISPUTES

### 5.10.1 CLAIMS AND DISPUTES

#### 5.10.1.1 Definitions:

**5.10.1.1.1** “Dispute” or “claim” means a written demand or written assertion by one of the Contracting parties seeking, as a matter of right, the payment of money in a sum certain, the extension of Contract Time, the adjustment or interpretation of Contract terms, or other relief arising under or relating to this Contract including, but not limited to, questions or doubts as to the true meaning of the Contract documents should any error, ambiguity or mistake be apparent in the Contract documents including quantity estimates. A claim arising under a Contract, unlike a claim relating to that Contract, is a claim that can be resolved under a Contract clause that provides for the relief sought by that claimant. A voucher, invoice or other routine request for payment that is not in dispute when submitted is not a claim or dispute under the Contract. The submissions may be converted to a claim under the Contract by complying with the submission requirements of the Contract documents, if it is disputed either as to liability or amount.

**5.10.1.1.2** A claim by the Contractor shall be made in writing and submitted to the District for a written decision. A claim by the District against the Contractor shall be made in writing.

#### 5.10.1.2 Procedure:

**5.10.1.2.1** Mediation. The Contractor and the District shall make a good faith attempt to resolve all claims and disputes that may arise from time to time during the performance of the Work. If the parties are unable to resolve the claim or dispute by direct negotiation or such other procedures as may be agreed upon at a Partnering Workshop or as required by law, and if the claim is not time barred, the parties agree first to attempt to settle the dispute by mediation administered at San Diego, California by the American Arbitration Association under its Construction Industry Mediation Rules, or by

such other agreed upon provider.

**5.10.1.2.2** Arbitration. If the mediation is unsuccessful in settling all disputes that are not otherwise time barred, and if both parties agree, any unresolved disputes may be resolved by arbitration administered at San Diego, California, by the American Arbitration Association under its Construction Industry Arbitration Rules, or by such other agreed upon provider, provided however, that any arbitration award shall be non-binding and advisory only. Any resultant agreements shall be documented and may be used as the basis for a Change Order as appropriate.

#### 5.10.1.3 Procedure for Protest of Disputed Work:

**5.10.1.3.1** Protect of Disputed Work: If the Contractor considers any Work required of it to be outside the requirements of the Contract, or if it considers any instruction, meaning, requirement, ruling or decision of the District or its representative to be unauthorized pursuant to the Contract, it shall within fourteen (14) calendar days after such demand is made, or instruction given, or receipt of a decision, file a written protest with the District stating clearly and in detail its objections and reasons therefor.

**5.10.1.3.2** The Contractor shall promptly comply with the Work required of it even though a written protest has been filed. If a written protest is not issued within fourteen (14) calendar days, said claim shall be time barred and the Contractor’s failure to provide such notice or the installation of any such Work without authorization shall be construed as relieving the District of any claim either for added costs or for extensions of time.

**5.10.1.3.3** The District will review the Contractor’s timely written protest and provide a decision within 45 days. If after reviewing the District’s decision, the Contractor still considers the Work required of it to be outside the requirements of the Contract, the Contractor shall notify the District in writing within seven (7) calendar days after receiving the decision that a formal claim will be issued. Within thirty (30) days of receiving the decision, the Contractor shall submit its claim in writing with the documents required as set forth in Subparagraphs 5.10.1.3 and 5.10.1.4, infra. Failure to furnish notification within seven (7)

days and all justifying documentation within thirty (30) days shall render the claim time barred and shall constitute a waiver of Contractor's claim.

**5.10.1.3.4** Upon receipt of the Contractor's formal claim including all required documentation supporting Contractor's position, the District or its designee will review the issue and within thirty (30) days from receipt of the Contractor's claim render a final determination. In the event the District does not respond, the claim shall be deemed denied.

**5.10.1.4** Certification:

**5.10.1.4.1** The Contractor shall submit under penalty of perjury with each claim its and each subcontractor's written certification that:

**5.10.1.4.1.1** The claim is made in good faith.

**5.10.1.4.1.2** Supporting data are accurate and complete to the best of the Contractor's knowledge and belief.

**5.10.1.4.1.3** The amount requested accurately reflects the Contract adjustment for which the Contractor believes the District is liable.

**5.10.1.4.1.4** If the Contractor is an individual, the certification shall be executed by that individual.

**5.10.1.4.1.5** If the Contractor is not an individual, the certification shall be executed by an officer or general partner of the Contractor having overall responsibility for the conduct of the Contractor's affairs.

**5.10.1.4.1.6** The Contractor understands that if a false claim is submitted, it will be considered fraud and the Contractor may be subject to criminal prosecution and any other available relief pursuant to Governmental Code section 12650, et seq.

**5.10.1.4.2** Submission of a claim, property certified, with all required supporting documentation, and written rejection or denial of all or part of the claim by the District, is a condition precedent to any action, proceeding, litigation, suit or demand for arbitration by Contractor.

**5.10.1.5** Claim Format:

**5.10.1.5.1** The Contractor shall submit the claim

justification in the following format:

**5.10.1.5.1.1** Summary of claim merit and amount and that Contract provision under which the claim is made.

**5.10.1.5.1.2** List of documents relating to the claim:

**5.10.1.5.1.2.1** Specifications.

**5.10.1.5.1.2.2** Plans.

**5.10.1.5.1.2.3** Clarifications/Requests for Information.

**5.10.1.5.1.2.4** Schedules.

**5.10.1.5.1.2.5** Other.

**5.10.1.5.1.3** Chronology of events and correspondence.

**5.10.1.5.1.4** Analysis of claim merit.

**5.10.1.5.1.5** Analysis of claim cost.

**5.10.1.5.1.6** Analysis of schedule delays.

**5.10.1.5.1.7** Cover letter and certification.

**5.10.1.5.1.8** Attachments:

**5.10.1.5.1.8.1** Specifications.

**5.10.1.5.1.8.2** Plans.

**5.10.1.5.1.8.3** Clarifications/Requests for Information.

**5.10.1.5.1.8.4** Correspondence.

**5.10.1.5.1.8.5** Schedules (all schedules relating to delays must be in a critical path method indicating the cause and occurrence of the delay. No other type of schedule will be accepted).

**5.10.1.5.1.8.6** Other.

**5.10.2** CONSTRUCTION CLAIMS LESS THAN \$375,000

**5.10.2.1** Construction Claims:

**5.10.2.1.1** These provisions are included in this

Contract as required by the California Public Contract Code:

**5.10.2.1.1.1** This section applies to all public work claims of Three Hundred Seventy-Five Thousand Dollars (\$375,000.00) or less which arise between a Contractor and the District.

**5.10.2.1.1.2** "Claim" means a separate demand by the Contractor for: (1) a time extension, (2) payment of money or damages arising from work done by or on behalf of the Contractor pursuant to the Contract for a public work and payment of which is not otherwise expressly provided for or the Contractor is not otherwise entitled to, or (3) an amount the payment of which is disputed by the District.

**5.10.2.1.2** For any claim filed under this section, the following requirements apply:

**5.10.2.1.2.1** The claim shall be in writing and include the documents necessary to substantiate the claim as defined in Section 5.10.1.4. Claims must be filed on or before the date of final payment. Nothing in this section is intended to extend the time limit or supersede notice requirements otherwise provided by Contract for the filing of claims.

**5.10.2.1.2.2** For claims of less than Fifty Thousand Dollars (\$50,000.00) the District shall respond in writing to any written claim within 45 days of receipt of the claim, or may request, in writing, within thirty (30) days of receipt of the claim, any additional documentation supporting the claim or relating to defenses to the claim the District may have against the Contractor. If additional information is thereafter required, it shall be requested and provided pursuant to this section, upon mutual agreement of the District and the Contractor. The District's written response to the claim, as further documented, shall be submitted to the Contractor within fifteen (15) days after receipt of the further documentation or within a period of time no greater than that taken by the Contractor in producing the additional information, whichever is greater.

**5.10.2.1.2.3** For claims of over Fifty Thousand Dollars (\$50,000.00) and less than or equal to Three Hundred Seventy-Five Thousand Dollars (\$375,000.00), the District shall respond in writing to all written claims within sixty (60) days of receipt of the claim, or may request, in

writing, within thirty (30) days of receipt of the claim, any additional documentation supporting the claim or relating to defenses to the claim the District may have against the Contractor. If additional information is thereafter required, it shall be requested and provided pursuant to this section, upon mutual agreement of the District and the Contractor. The District's written response to the claim, as further documented, shall be submitted to the Contractor within thirty (30) days after receipt of the further documentation, or within a period of time no greater than that taken by the Contractor in producing the additional information or requested documentation, whichever is greater.

**5.10.2.1.2.4** If the Contractor disputes the District's written response, or the District fails to respond within the time prescribed, the Contractor may so notify the District, in writing, either within fifteen (15) days of receipt of the District's response or within fifteen (15) days of the District's failure to respond within the time prescribed, respectively, and demand an informal conference to meet and confer for settlement of the issues in dispute. Upon a demand, the District shall schedule a meet and confer conference within thirty (30) days for settlement of the dispute.

**5.10.2.1.2.5** If following the meet and confer conference, the claim or any portion remains in dispute, the Contractor may file a claim as provided in Chapter 1 (commencing with Section 900) and Chapter 2 (commencing with Section 910) of Part 3 of Division 3.6 of Title 1 of the Government Code. For purposes of those provisions, the running of the period of time within which a claim must be filed shall be tolled from the time the Contractor submits its written claim pursuant to Subparagraph 5.10.2.1.2.1, above until the time that claim is denied as a result of the meet and confer process, including any period of time utilized by the meet and confer progress.

**5.10.2.1.2.6** The proceeding sections do not apply to non-Contract claims and do not effect any applicable time periods for filing such claims.

**5.10.2.2** Unless this Contract provides otherwise, all claims, counter-claims, disputes and other matters in question between the District and the Contractor arising out of or relating to this Contract or its breach shall be

decided in a court of competent jurisdiction within the County of San Diego in the State of California and shall be governed by the laws of the State of California.

## **ARTICLE 5.11 – TERMINATION OR SUSPENSION OF THE CONTRACT**

### **5.11.1 TERMINATION OR SUSPENSION FOR CAUSE**

**5.11.1.1** If the Contractor fails to begin the delivery of the material, to commence Work as provided in the Contract, to make delivery of material promptly as ordered, to maintain the rate of delivery of material or progress of the Work in such a manner as in the opinion of the Engineer will insure a full compliance with the Contract Time, files for bankruptcy protection, or if in the opinion of the Engineer the Contractor is not carrying out the provisions of the Contract in their true intent and meaning or persistently disregard laws, ordinances, Contract terms or rules or regulations or orders of a public authority having jurisdiction, persistently fails to timely pay its subcontractors, materialmen, or suppliers as required by law or otherwise has breached a provision of the Contract documents, written notice will be served on the Contractor to provide satisfactory compliance with the Contract within a specified time period. In the event Contractor neglects or refuses to comply with such notice, the Engineer may with the written consent of the Executive Director and consent of the Board evidenced by resolution, terminate the operation of all or any part of the Contract, or the Engineer may in its discretion after such notice, at the expense and for the account of the Contractor, cause to be performed any part of the Work, or purchase any or all of the material included in the Contract or required for its completion, without terminating the Contract.

**5.11.1.2** If the Contractor is debarred by the Board pursuant to District ordinance, this Contract and any other existing Contract by and between the District and the Contractor shall be terminated. Notwithstanding the foregoing, the Board may continue this Contract, and any other existing Contract, upon advice from the Executive Director as to the effect of termination of this Contract.

**5.11.1.3** Upon termination, the Engineer may, at its discretion, take possession of all or any part

of the machinery, tools, appliances, material and supplies used in the Work covered by the Contract or that have been delivered by or on account of the Contractor for use in connection therewith and the same may be used either directly by the District or by other parties for it, in the completion of the Work suspended; or the District may employ other parties to perform the Work or may substitute other machinery or material or purchase the materials contracted for in such manner as it may deem proper or hire such force and buy such machinery, tools, appliances, materials and supplies at the Contractor's expense as may be necessary for the proper conduct and completion of the Work. When the District terminates the Contract for cause, the Contractor shall not receive future payments until the Work is completed. Any cost to the District in excess of the Contract arising from the suspension of the Contract, or from Work performed or purchases made by the District either before or after suspension and required on account of the failure of the Contractor to comply with this Contract or other orders of the Engineer issued in pursuance thereof, and any costs incurred by the District in locating and/or Contracting with a replacement Contractor, shall be charged to the Contractor and its sureties, who shall be liable therefor. The Contractor shall maintain all insurance required by the Contract as if the Contract had been satisfactorily completed and accepted by the District.

**5.11.1.4** A special lien to secure the claims of the District in the event of termination for cause of the Contract is hereby created against any property of the Contractor taken into the possession of the District under the terms hereof, and such lien may be enforced by a sale of such property under the direction of the Board and the proceeds of the sale, after deducting all expenses thereof, and connected therewith, shall be credited to the Contractor. If the net credits shall be in excess of the claims of the District against the Contractor, the balance will be paid to the Contractor or its legal representatives.

**5.11.1.5** The Contractor shall not make any disposition of the plant, machinery, tools, appliances, supplies or materials used on or in connection with the Work, either by sale, conveyance or encumbrance, inconsistent with the special lien of the District expressly created by this Contract.

**5.11.1.6** The decision of the Engineer, when approved by the Executive Director and by the Board evidenced by resolution, shall be final and binding upon both parties. In the event it is determined that cause did not exist for termination pursuant to these provisions, the termination shall be without further notice considered termination for convenience. Suspension of the Contract or any part thereof, shall operate only to terminate the right of the Contractor to proceed with the Work covered by the Contract or the suspended portions thereof. The provisions of the Contract permitting the District to make changes and to make proper adjustment of accounts to cover any increase or decrease of cost on account of such changes, and all other stipulations of the Contract except those giving the Contractor the right to proceed with Work on the item covered by the suspension, shall be and remain in full force and effect after such suspension and until the Contract shall have been completed and final payment or final adjustment of account made.

**5.11.2** TERMINATION OR SUSPENSION FOR CONVENIENCE. The District may, without cause, order the Contractor in writing to suspend, interrupt or terminate performance of the Work in whole or in part for such period of time as the District may determine. An adjustment may be made for an increase in the cost of performance of the Contract including profit on the increased cost of performance, if any, caused by any such suspension or interruption or termination. An equitable adjustment may be made of the price or prices specified in the Contract relating to the portion of the Work not suspended, interrupted or terminated by the notice of suspension, interruption or termination. No adjustment shall be made to the extent:

**5.11.2.1** That performance is, was or would have been so suspended, delayed or interrupted by another cause for which the Contractor is responsible; or

**5.11.2.2** An equitable adjustment is made or denied under another provision of this Contract.

**5.11.3** EFFECT OF SUSPENSION, INTERRUPTION OR TERMINATION FOR CAUSE OF CONVENIENCE

**5.11.3.1** Any such suspension, interruption or

termination for cause or convenience shall be effected by delivery to the Contractor of a written notice of suspension, interruption or termination specifying the extent to which performance of Work under the Contract is suspended, interrupted or terminated and the date upon which such suspension, interruption or termination becomes effective. After receipt of the notice of suspension, interruption or termination and except as otherwise directed by the District, the Contractor shall:

**5.11.3.1.1** Stop Work under the Contract on the date and to the extent specified in the notice of suspension, interruption or termination;

**5.11.3.1.2** Place no further orders or subcontracts for materials, services or facilities except as necessary to complete the portion of the Work under the Contract which is not suspended, interrupted or terminated;

**5.11.3.1.3** Place no further equipment at the Project except as necessary to complete the portion of the Work under the Contract which is not suspended, interrupted or terminated;

**5.11.3.1.4** Terminate all orders or subcontracts to the extent they relate to the performance of Work suspended, interrupted or terminated by the notice of suspension, interruption or termination;

**5.11.3.1.5** Assign to the District in the manner, at the times, and to the extent directed by the District, all the right, title and interest of the Contractor under the orders and subcontracts so suspended, interrupted or terminated. The District shall have the right, in its discretion, to settle or pay any or all claims arising out of the suspension, interruption or termination of such orders and subcontracts;

**5.11.3.1.6** Settle all outstanding liabilities and all claims arising out of such suspension, interruption or termination of orders and subcontracts, with the approval or ratification of the Board to the extent the Board may so require. The Board's approval or ratification shall be final for all purposes of this clause;

**5.11.3.1.7** Transfer title to the District, and deliver in the manner, at the times, and to the extent, if directed by the District, the fabricated or unfabricated parts, work in process, completed Work, supplies and other materials



produced as a part of, or acquired in connection with the performance of, the Work terminated by the notice of suspension, interruption or termination, and the completed or partially completed plans, drawings, information and other property which, if the Contract had been completed, would have been required to be furnished to the District;

**5.11.3.1.8** Use its best efforts to sell, in the manner, at the times, and to the extent, and at the price or prices that the District direct or authorized, any property of the types previously referred to herein, but the Contractor shall not be required to extend credit to any purchaser and may acquire any such property under the conditions prescribed and at a price or prices approved by the District. The proceeds of any such transfer or disposition shall be applied in reduction of any payments to be made by the District to the Contractor under this Contract or shall otherwise be credited to the price or cost of the Work covered by this Contract or paid in such other manner as the District may direct;

**5.11.3.1.9** Complete performance of such part of the Work as shall not have been suspended, interrupted or terminated by the notice of suspension, interruption or termination;

**5.11.3.1.10** Take such action as may be necessary, or as the District may direct, for the protection and preservation of the property related to this Contract which is in the possession of the Contractor and in which the District has or may acquire an interest;

**5.11.3.1.11** The Contractor shall maintain the Work site and provide such ingress and egress for local resident or tenants or the public as may be necessary during the period of suspended work or until the Contract has been declared terminated; and

**5.11.3.1.12** Maintain all required insurance as if the Contract had been satisfactorily performed and accepted by the District.

**5.11.3.2** After receipt of the notice of suspension, interruption or termination, the Contractor shall submit to the District a certified suspension, interruption or termination claim. Such claim shall be submitted promptly but in no event later than ninety (90) days from the effective date of the notice of suspension, interruption or termination. If the Contractor fails

to submit a suspension, interruption or termination claim at any time after such ninety (90) day period, the District may determine, on the basis of information available to it, the amount, if any, due to the Contractor. The District shall then pay to the Contractor the amount so determined.

**5.11.3.3** After receipt of a certified claim, the District and the Contractor may agree upon the whole or any part of the amount or amounts to be paid to the Contractor because of the total or partial suspension, interruption or termination of the Contract. The amount may include a reasonable allowance for profit on Work performed. However, such agreed amount or amounts, exclusive of settlement costs, shall not exceed the total Contract price as reduced by the amount of payments otherwise made and as further reduced by the Contract price of Work not suspended, interrupted or terminated and any claims the District may have against the Contractor. Nothing in Subparagraph 5.11.3.5 of this section, shall be deemed to limit, restrict or otherwise determine or affect the amount or amounts which may be agreed upon to be paid to the Contractor pursuant to this paragraph.

**5.11.3.4** After receipt of a certified claim, if the Contractor and District fail to agree on the amounts to be paid to the Contractor, the District shall determine, on the basis of the information available to it the amount, if any, due to the Contractor by reason of the suspension, interruption or termination and shall pay the Contractor the amount which shall be determined as follows:

**5.11.3.4.1** For all work specified in the Contract which is performed before the effective date of the notice of suspension, interruption or termination, the total of:

**5.11.3.4.1.1** The reasonable cost to the Contractor, without profit, for all Contract Work performed prior to the notice of suspension, interruption or termination, including the Work done to secure the project for termination. In determining the reasonable cost, the District may utilize the schedule of values, Contract unit prices, Contract lump sum, the percentage of Work completed and any other method available to it. For purposes of determining reasonable costs, deductions will be made for the cost of materials to be retained by the Contractor, amounts realized by the sale of materials, and

for other appropriate credits against the cost of the Work. When in the opinion of the District the cost of an item of Work is unreasonably high, the reasonable cost to be allowed will be the estimated reasonable cost of performing such Work in compliance with the requirements of the plans and specifications and excessive actual cost shall be disallowed.

**5.11.3.4.1.2** Reasonable cost will include a reasonable allowance for project overhead and general administrative overhead not to exceed a total of ten percent (10%) of direct costs of such Work.

**5.11.3.4.1.3** A reasonable allowance for profit on the cost of the Work performed as determined under Subparagraph 5.11.3.4.1.1 provided the Contractor established to the satisfaction of the District that it would have made a profit had the Contract been completed and provided further, that the profit allowed shall in no event exceed five percent (5%) of the cost of the Work completed.

**5.11.3.4.1.4** The reasonable cost to the Contractor of handling material returned to the vendor, delivered to the District or otherwise disposed of as directed by the District.

**5.11.3.5** In no event shall the District be liable for costs incurred by the Contractor or any of its subcontractors after receipt of a notice of suspension, interruption or termination. Such non-recoverable costs include, but are not limited to, anticipated profits on the Contract post-suspension, post-interruption or post-termination, employee salaries, administrative expenses, overhead or unabsorbed overhead, the costs of preparing and submitting the bid, attorneys' fees or other costs relating to the prosecution of a claim or lawsuit, pre-judgment interest, or any other expense which is not reasonable or authorized under this subparagraph of this section.

**\*\*\* END OF SECTION \*\*\***



**Addendum No. 8 to Spec. No. 2020-15**

---

**SAN DIEGO UNIFIED PORT DISTRICT**  
*Procurement Services Department*  
1400 Tidelands Avenue  
National City, California 91950  
(619) 686-6392

**TO:** All Prospective Bidders

**FROM:** Mark Adams  
Procurement Analyst II

**DATE:** February 17, 2022

**SUBJECT:** **Addendum No. 8 to Specification No. 2020-15 for Structural Pile Repairs to Navy Pier, San Diego, California**

---

The Bid Opening Date has **NOT** been changed.

at

**San Diego Unified Port District**  
**General Services Building, Second Floor**  
**1400 Tidelands Avenue**  
**National City, California 91950**

on

**March 1, 2022 @ 2:00 p.m.**

Make all revisions to the specifications and contract documents as stated herein. Insofar as original specifications and other documents are at variance with this Addendum, the Addendum shall govern.

This Addendum consists of three (3) pages.

**TECHNICAL SPECIFICATIONS CHANGES:**

Section 6.0 Technical Specifications - SECTION 01 27 00 – MEASUREMENT AND PAYMENT

a. **DELETE:** Paragraph 1.3.D

**Addendum No. 8 to Spec. No. 2020-15**

---

**b. REVISE:**

Revise Paragraphs 1.4.B and C to read as follows:

- B. Payment for MOBILIZATION AND DEMOBILIZATION will be made at the lump sum price named in the Bid Schedule, which price shall constitute full compensation for conforming to the requirements of Section 01 71 13, "Mobilization and Demobilization", as defined within these Contract Documents, with the sole exclusion of the payments to be made as defined herein for the other items in the Bid Schedule.
- C. Mobilization and demobilization cost shall not exceed 5% of the total construction cost.

**DRAWING CHANGES:****1. REMOVE:**

Remove "Sheet 8" from DWG# EM-2020-03

**2. ADD:**

Add "Sheet 8A" to DWG# EM-2020-03 to show lap splice schedule.

Added Drawing Sheet is attached to this Addendum.

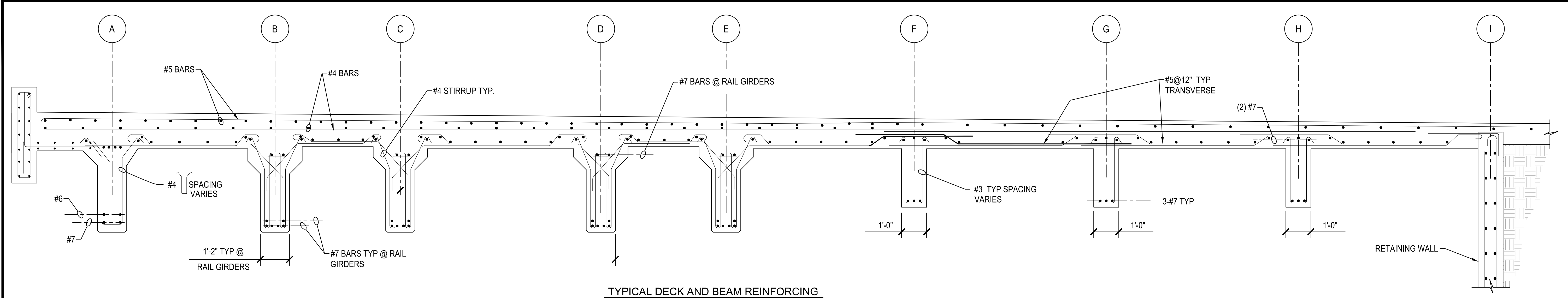

TYPICAL DECK AND BEAM REINFORCING  
SCALE: 1/2"=1'-0"

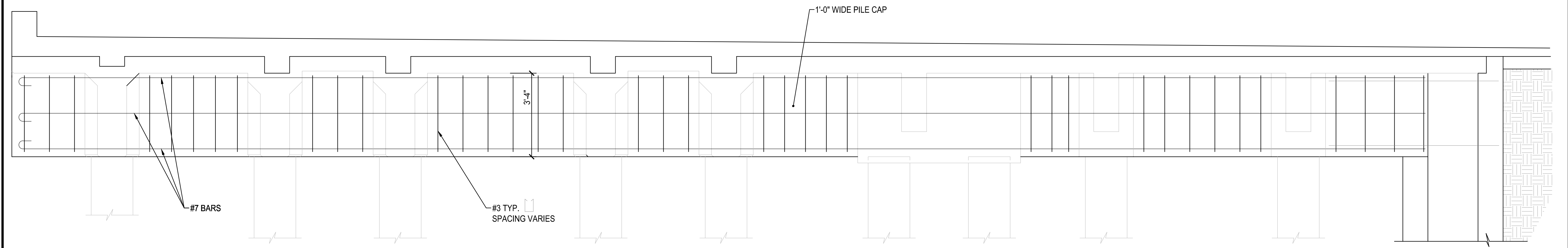

TYPICAL PILE CAP REINFORCING  
SCALE: 1/2"=1'-0"

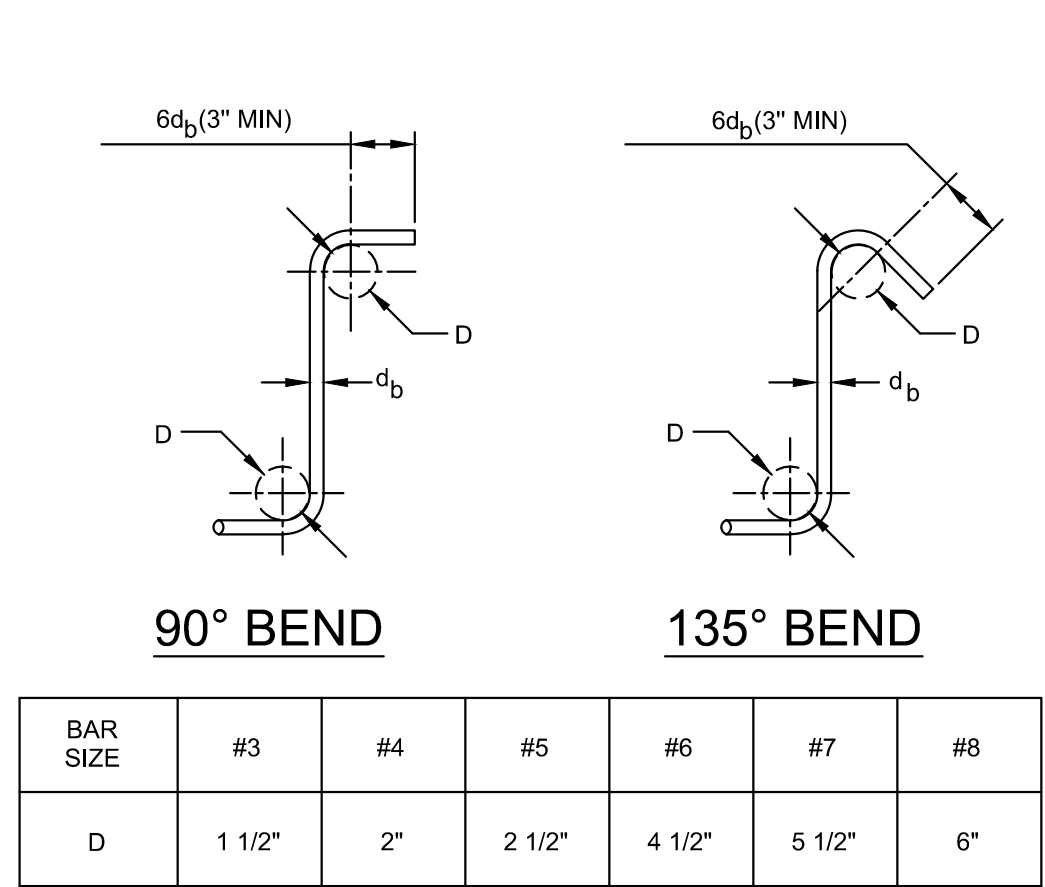

BAR SIZE	#3	#4	#5	#6	#7	#8
D	1 1/2"	2"	2 1/2"	4 1/2"	5 1/2"	6"

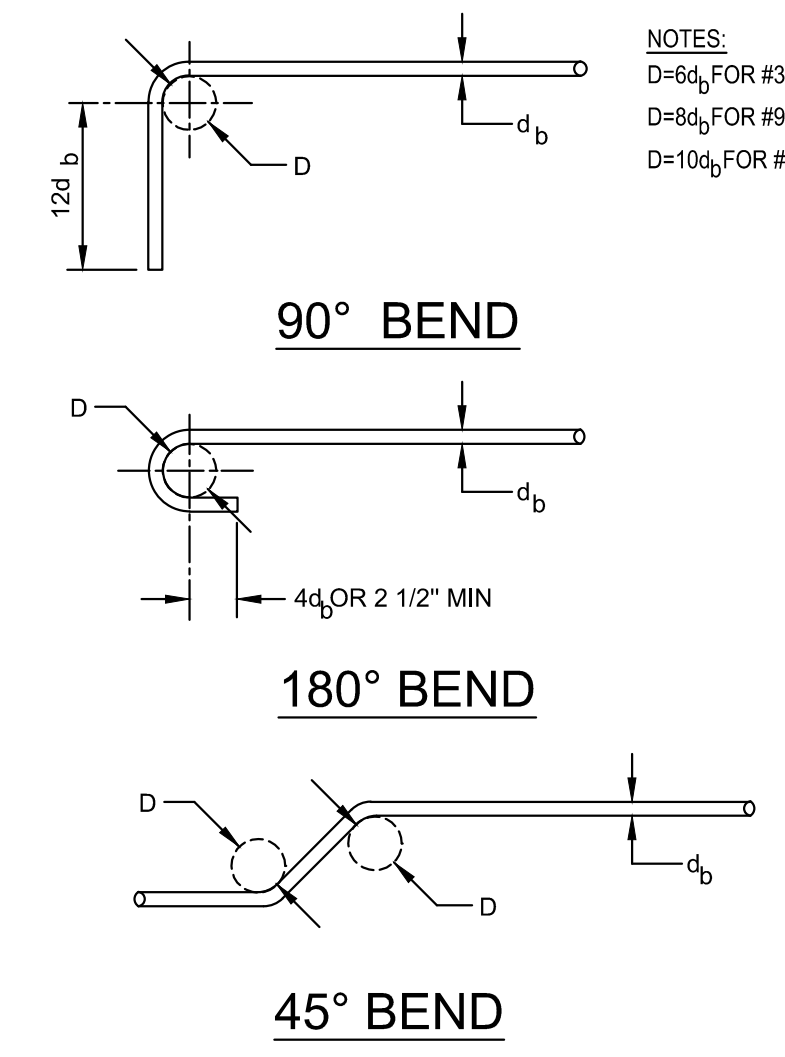

2 TYPICAL REINFORCING BENDS  
NO SCALE

NOTES:  
D=6db FOR #3 THRU #8  
D=8db FOR #9 THRU #11  
D=10db FOR #14 AND #18

CONCRETE STRENGTH	f <sub>c</sub> = 5000 PSI		
	CLASS "B"		
CLASS OF LAP SPLICE	BAR SIZE	OTHER BARS	
		UNCOATED	EPOXY COATED
	#3	22	20
	#4	29	27
	#5	36	34
	#6	43	40
	#7	63	58
	#8	72	67
	#9	81	75
	#10	91	83

- WHERE CLEAR SPACE BETWEEN BARS LAP SPLICED AT ANY SECTION IS LESS THAN 2 BAR DIAMETERS, OR WHERE THE BAR COVER IS LESS THAN OR EQUAL TO THE BAR DIAMETER, INCREASE THE LAP BY 50%
- TOP BARS ARE HORIZONTAL BARS WITH MORE THAN 12 INCHES OF CONCRETE CAST BELOW THE BARS.

3 REINFORCING LAP SPLICES  
NO SCALE

ALLOWABLE BAR DIAMETER (IN)		
BAR SIZE	ORIGINAL Ø	MINIMUM Ø
#3	.375	.30
#4	.500	.40
#5	.625	.50
#6	.750	.60
#7	.875	.70
#8	1.00	.80
#9	1.128	.90

4 ALLOWABLE BAR SCHEDULE  
NO SCALE

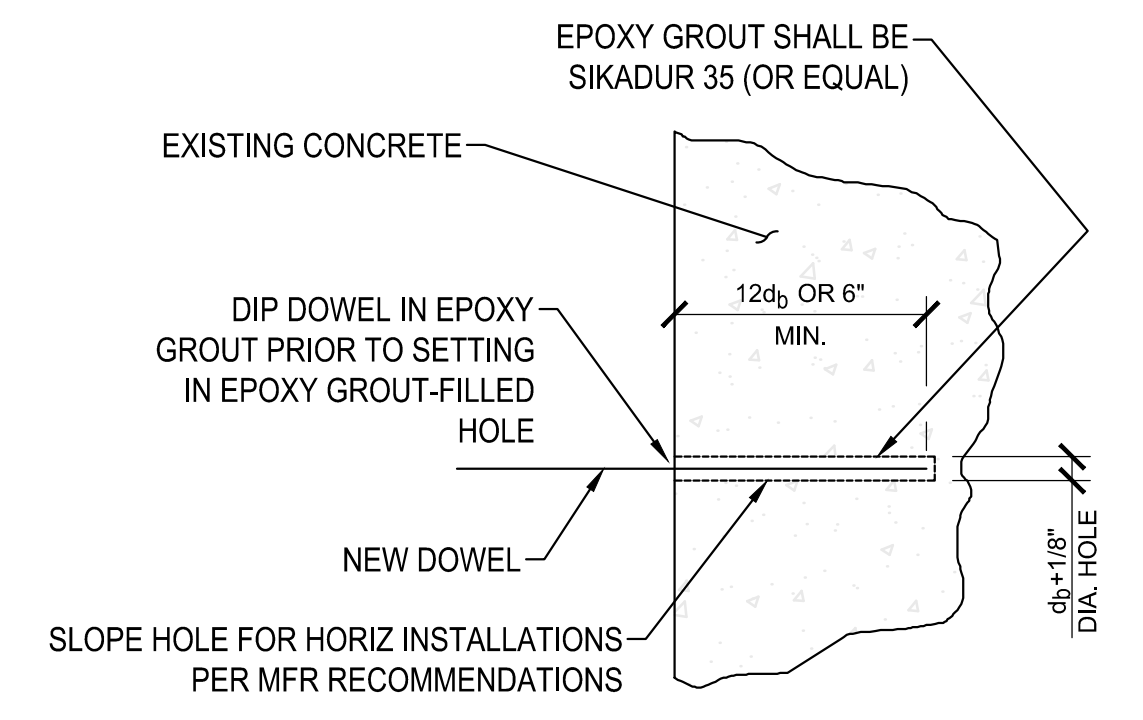

5 TYPICAL EPOXY DOWEL  
NO SCALE

RECORD DRAWING  
REVIEWED BY:  
ENGINEER OF RECORD  
DATE

NOTE:  
THIS DRAWING MAY BE A REDUCED SCALE PRINT OF THE ORIGINAL DRAWING. UTILIZE GRAPHIC SCALES TO VERIFY IF DRAWING IS A REDUCTION, AND ADJUST SCALES ACCORDINGLY TO THE GRAPHIC SCALES SHOWN.

SPEC NO. 2020-15	WBS NO. MC-0082-01	ADD LAP SPLICE INFO FOR EPOXY COATED	02/11/22
REFERENCES			
PROJECT ENGINEER NOEMI AQUINO			
CONTRACTOR -			
CONSTRUCTION STARTED -			
CONSTRUCTION COMPLETED -			
COST -	INSPECTOR -	REVISIONS	DATE / APPROVED



DESIGNED TEG	APPROVAL RECOMMENDED 02/16/2022
DRAWN TEG	NOEMI AQUINO PROJECT MANAGER
CHECKED JVP	APPROVED Chris Brooke 2/17/2022 CHRISTOPHER BROOKE ENGINEERING/CONSTRUCTION DEPARTMENT MANAGER

SAN DIEGO UNIFIED PORT DISTRICT		DATE DECEMBER 16, 2021
STRUCTURAL PILE REPAIRS TO NAVY PIER		A/E NO. S-2
TYPICAL DETAILS AND PIER SECTIONS		SHEET 8A OF 28
		DRAWING NO. EM-2020-03
		REV. -